

SC Product Specification

Issue 1
March 2002

SC Product Specification

General Definition:

The SC Connector Product is a robust optical connector designed to support Telecom and Datacom networks. The connector family includes but not limited to connectors, adapters, attenuators, modular adapters, jumpers, an assortment of connector modules and panels, and installation tool kits and consumable kits. The OFS SC Connector is a push-pull connector that uses 4-position tuning, which can be accomplished by simply rotating the grip 90 degrees. This high performance SC connector is versatile for both singlemode and multimode applications.

Terms of Specification:

The specification document is intended to provide users of OFS Fitel SC Connector products a level of confidence and means of understanding the characteristics of purchased product. The product is designed and should be manufactured according to the specification document. The product specification serves as a guideline to the features and performance of the product, and is subject to change without notice.

Definition of Products:

SC Jumper Connectors: Robust family of connectors designed to mount on 1.6 – 3.0 mm fiber cordage and intended to meet the Telcordia GR-326-CORE, Issue 3, for Type I Media (reinforced jumper cordage).

SC BTW Connectors: SC connectors designed for 900 micron buffered fiber. This product is intended to meet Telcordia GR-326-CORE, Issue 3 for Type II Media (900 micron buffered fiber).

SC Jumpers: Connectorized 1.6mm and 3.0mm cordage in various lengths and fiber counts. Jumpers are produced in a vast array of hybrid configurations allowing interconnection between SC based product and other connector styles. These products are intended to meet Telcordia GR-326-CORE, Issue 3 for Type I Media.

SC Adapters: Two-port configuration for joining two SC connectors. The adapter contains the alignment sleeve for the precise alignment of the connector ferrules. Available in simplex, duplex and higher density configurations based on application needs. See also 0dB Modular Adapters.

SC Modular Adapters & Attenuators: Attenuator products are configured as a Build-On style or a Modular Adapter. The Type II Modular Adapters consist of single port adapters configured from 2 parts: a base and a cap. Two bases are available: SC or ST[?]. The cap is available in 3 connector versions, SC, ST[®] and FC and in 0-dB and attenuated values. Build-On Attenuators are one-piece designs that combine an SC Connector on one end and an adapter on the other, and are available in several attenuation values. Each attenuator product reduces optical power internally.

SC-LC Converter: The “in-line” converter is a combination of an SC connector and an LC receptacle. This essentially allows an LC connector to mated into an SC adapter.

Product Identification:

SC products are easy to identify in accordance with industry standards:

Blue represents singlemode

Beige represents multimode

Green represents singlemode APC (Angled End Face)

A & B port identification is on duplex adapters in accordance with TIA 568

[?] ST is a registered trademark of OFS Fitel

Revision History

Date	Rev.	Name	Comments
4/5/2002	Issue 1	TBM	Initial Release

Table of Contents

1.0 – SC CONNECTOR SPECIFICATION.....	1
1.1 – SC Connector Application	2
1.2 – SC Connectors: Exploded View	2
1.2a – SC Jumper Connectors	2
1.2b – SC BTW (Behind the Wall) Connector	2
1.3 – SC Connector Footprint Dimensions	3
1.4 – SC Connector Materials.....	3
1.5 – SC Connector Illustrations.....	4
1.5a – SC Simplex Connector.....	4
1.5b – SC Duplex Connector	4
1.5c – SC Connector Specifications for Intermateability.....	5
1.6 – Ferrule Surface Requirements	6
1.7 – SC Connector Ferrule Extension and Contact Force.....	7
1.8 – SC Connector Coding (or equivalent).....	7
1.9 – SC Connector Color Coding.....	7
2.0 – SC ADAPTER SPECIFICATION.....	8
2.1 – SC Simplex and Duplex Adapter: Iso View	9
2.1a – SC Duplex Adapter	9
2.1b – SC Simplex Adapter	9
2.2 – SC Adapter Footprint Dimensions	9
2.2a – SC Duplex Adapter	9
2.2b – SC Simplex Adapter	9
2.3 – Panel Cutout Dimensions for Mounting SC Adapters	10
2.4 – SC Adapter Materials	10
2.5 – SC Adapter Illustrations	11
2.5a – SC Simplex Adapter	11
2.5b – SC Duplex Adapter.....	12
2.5c – SC Adapter Specifications for Intermateability.....	12
2.6 – SC Adapter Coding Scheme.....	13
2.7 – SC Adapter Color Coding	13
3.0 –MODULAR ADAPTERS AND ATTENUATORS.....	14
3.1 – Modular Adapter System (UBO): Exploded View.....	15
3.2 – Modular Adapter SC “.....”	16
3.3 – Modular Adapter ST “Base” Footprint	16
3.4 – Modular Adapter SC “Cap” Footprint.....	17
3.5 – Modular Adapter and Attenuator System Materials and Specifications	17
3.6 – Modular Adapter “Base” Coding Scheme	18
3.7 – Modular Adapter “Cap” Coding Scheme.....	18
3.8 – ASCS Series Modular Attenuator “Caps”.....	18
3.9 – ASCM Series Modular Attenuator “Caps”.....	21
3.10 – ASCLR Series Modular Attenuator “Caps”.....	22
3.11 – A3060N1 Series Modular Attenuator “Caps”.....	22
3.12 – Modular Adapter Spectral Flatness	23
3.13 – Modular Adapter Power Divergence.....	23
3.14 – Modular Adapter Compliance to GR-910 and GR-326.....	24
4.0 – SC BUILD-ON ATTENUATORS	25
4.1 – Build-On Attenuator System Application.....	26
4.2 – Build-On Attenuator Footprint Illustration	26
4.3 – Build-On Attenuator Materials and Specifications	27

4.4 – Build-On Attenuator Coding Scheme.....	27
4.5 – ABSCS Series Build-on Attenuator	28
4.6 – ABSCA Series Build-on Attenuator	28
5.0 – SC TERMINATOR SPECIFICATION.....	29
5.1 – SC Terminator Application.....	30
5.2 – Terminator Information and Performance.....	30
6.0 – SC-LC CONVERTER.....	31
6.1 – SC-LC Converter Application	32
6.2 – SC-LC Converter Footprint Illustration.....	32
6.3 – SC-LC Converter Information and Performance.....	32
7.0 – SC JUMPER SPECIFICATION.....	33
7.1 – SC Simplex Jumper.....	34
7.2 – SC Simplex Jumper Exploded Assembly.....	34
7.3 – SC Duplex Jumper Exploded Assembly	35
7.4 – SC Duplex MM Jumper as per TIA/EIA.....	35
7.5 – SC Jumper/Connector Materials	36
7.6 – Cordage Technical Specifications	36
7.7 – SC Singlemode Ferrule Endface Geometry	37
7.8 – SC APC Ferrule End-face Geometry	38
7.9 – SC APC Ferrule/Angle Orientation	39
7.10 – SC Factory Made PC Patch Cord – Specifications	39
7.11 – Visual Inspection Criteria for Fiber Optic Connectors with Fiber.....	40
7.12 – SC SM Jumper Tuning Configuration	41
7.13 – SC Jumpers – Available Configurations.....	42
7.14 – SC Jumper Coding Scheme.....	43
7.15 – SC Jumper Color Coding.....	43
8.0 – SC TOOLS, KITS, AND CONSUMABLES.....	44
8.1 – Ordering Information	45

1.0 – SC Connector Specification

1.1 – SC Connector Application

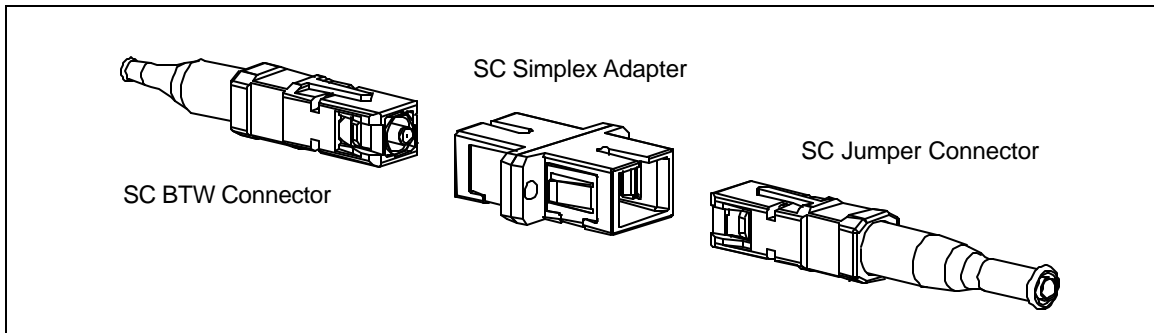

1.2 – SC Connectors: Exploded View

1.2a – SC Jumper Connectors

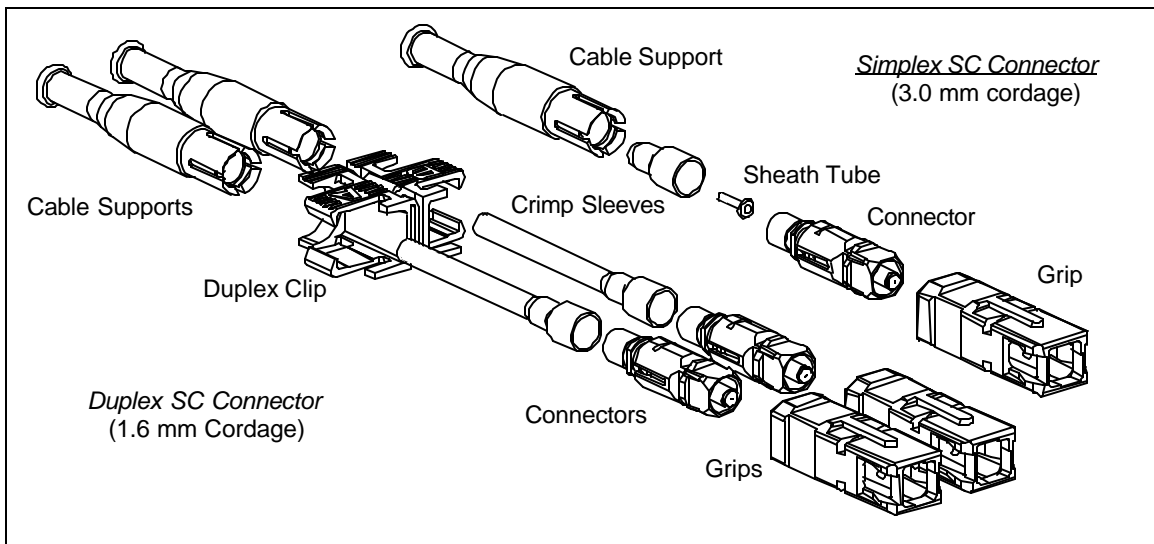

1.2b – SC BTW (Behind the Wall) Connector

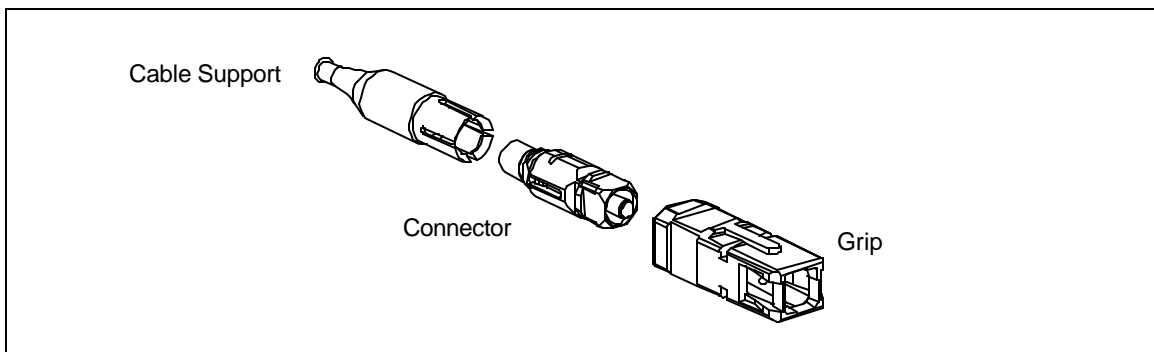

1.3 – SC Connector Footprint Dimensions

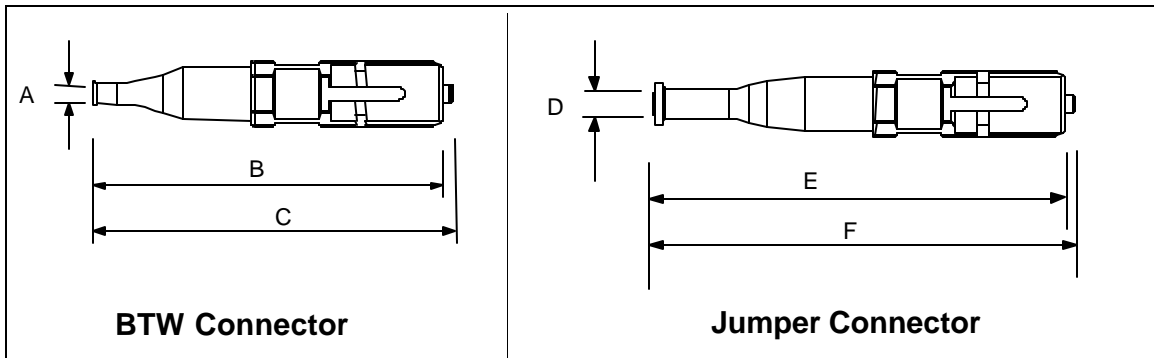

REF.	DIMENSIONS	
	Minimum	Maximum
A	0.9	1.0
B	-	56
C	-	58
D	1.8	3.2
E	-	58
F	-	60

1.4 – SC Connector Materials

Connector Part	Material	UL 94 Rating	Oxygen Index
Ferrule	Zirconia	-	-
Barrel	Stainless Steel	-	-
Cable Support Boot	Engineering Plastics	V-0	29
Spring	Stainless Steel	-	-
Plug Frame	Engineering Plastics	V-0	34
Duplex Clip	Engineering Plastics	V-0	35
Grip	Engineering Plastics	V-0	34
Buffer Boot	Engineering Plastics	V-0	29
Cable Retention Member	Ni-plated Brass	-	-
Crimp Sleeve	Anodized Aluminum	-	-
Sheath Tube	Ni-plated Brass	-	-

1.5 – SC Connector Illustrations

1.5a – SC Simplex Connector

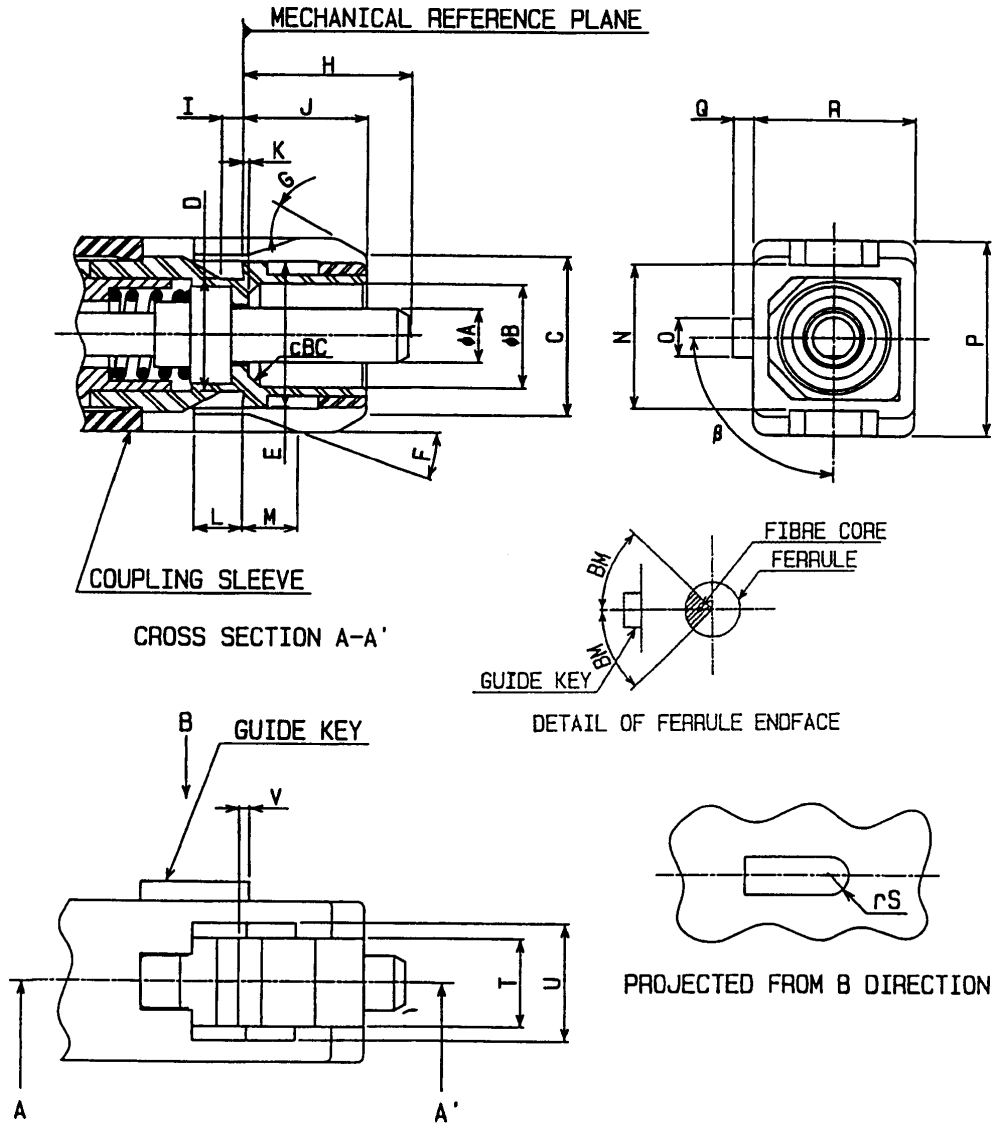

1.5b – SC Duplex Connector

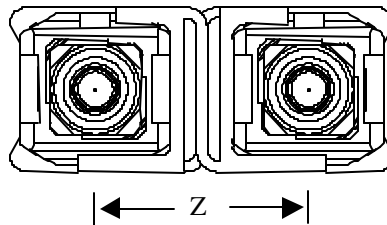

1.5c – SC Connector Specifications for Interchangeability

Ref.	Dimensions (mm.)		Notes
	Min.	Max.	
A	2.4985	2.4995	
B	4.8	4.9	
C	6.8	7.4	
D	-	5.3	
E	6.7	6.8	
F	19°	23°	
G	25°	35°	
H	7.15	7.85	1, 2
I	0.8	1.2	
J	5.3	5.5	
K	-	0.05	3
L	2.11	-	4
M	2.0	2.8	4
N	6.6	6.8	
O	1.6	1.8	
P	8.79	8.99	
Q	0.8	1.0	
R	7.19	7.39	
S	-	0.9	Radius
T	4.05	4.15	
U	5.4	-	
V	-0.5	0.57	3
BC	0	0.5	Chamfer
Z	12.7		5

Notes:

1. Ferrule compression force shall be from 7,8 N to 11,8 N, when the ferrule is compressed to a point where H is $7,00 \pm 0,1$ mm.
2. This value shows the dimension after the ferrule is polished and in the unmated condition.
3. The negative dimension refers to the position of the inside bottom plane left – direction relative to the mechanical reference plane
4. The coupling sleeve can move in both the right and left directions to engage the adapter. Dimension M is measured when the coupling sleeve is in its extreme right position.
5. Each of the units in the duplex connector shall comply with all of the dimensions in Figure 1.5a.
6. Where a tolerance of form is not specified, the limits of the dimensions for a feature control the form as well as the size.
7. Where interrelated features of size (features shown with a common axis or center plane) have no geometric tolerance of location or run out specified, the limits of the dimensions for a feature control the location tolerance as well as the size.
8. Where perpendicular features (features shown at right angles) have no geometric tolerance of orientation or run out specified, the limits of the dimensions for a control the orientation tolerance as well as the size.

1.6 – Ferrule Surface Requirements

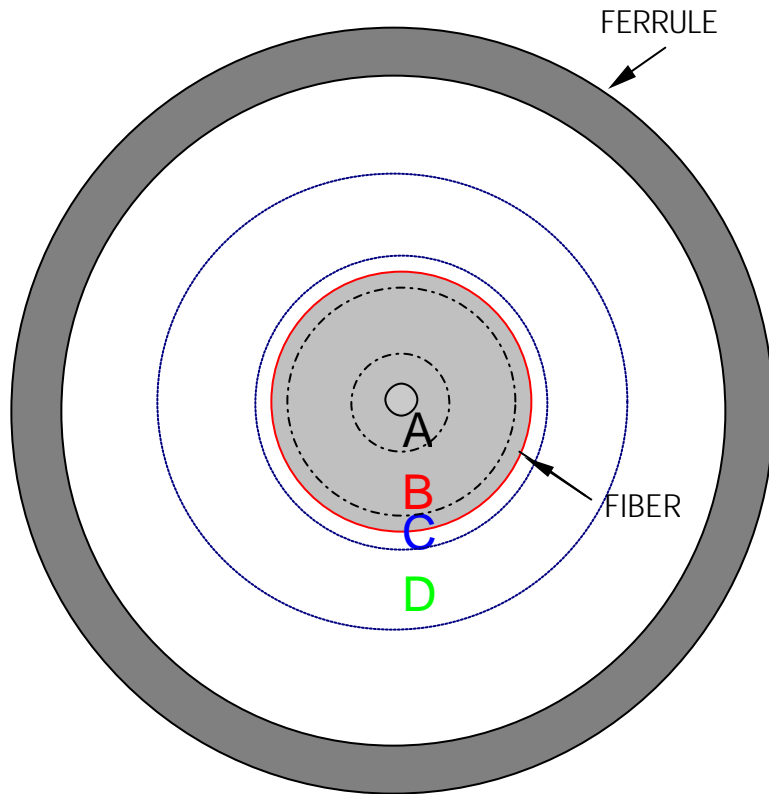

Figure not-to-scale.

Magnification (minimum)	200x
Resolving Power	1 μm
Numerical Aperture	0.3

INSPECTION CRITERIA: SINGLEMODE	
A Core Zone	
Diameter	0 - 25 μm
Scratches (SM)	None
Pits & Chips	None
Contamination	None
Crack	None
Other	
B Cladding Zone	
Diameter	25 - 120 μm
Scratches (SM)	Up to 3 scratches of any length, 1-3 μm width
Pits & Chips	Unlimited (<2 μm dia.)
Contamination	None
Crack	None
C Epoxy Zone	
Diameter	120 - 130 μm
Scratches (SM)	Unlimited
Pits & Chips	Unlimited (<5 μm dia.)
Contamination	No loose particles
D Contact Zone	
Diameter	130 - 250 μm
Scratches (SM)	Unlimited
Pits & Chips	Unlimited
Contamination	No loose particles

INSPECTION CRITERIA: SINGLEMODE_APC same as singlemode above except as noted.	
A Core Zone	
Scratches	Any length, 2-3 μm width if

Notes:

- For optical performance, see Table 5.10 of Factor Made PC Patch Cord - Specification.
- Proposed measurement method IEC 86B WG4 61300-3-X dated October 2001.
- Since loose particles may be introduced during the inspection process, cleaning the end-face is recommended prior to insertion into the microscope. Cleaning procedures are found in Section 4.3 of Telcordia GR-326-CORE, Issue 3, September 1999.
- Figure and singlemode Table proposed IEC 86B WG6 Level 2 Specification for polished fiber end faces. Scratches and defects $\geq 1.0 \mu\text{m}$ are not counted. Dated October 2001, except 2 μm scratch width & pit diameter was 1 μm .
- Outside the 250 μm contact zone there are no requirements for visual inspection since defects found in this region have no influence on the optical performance of PC polished ferrules.

1.7 – SC Connector Ferrule Extension and Contact Force

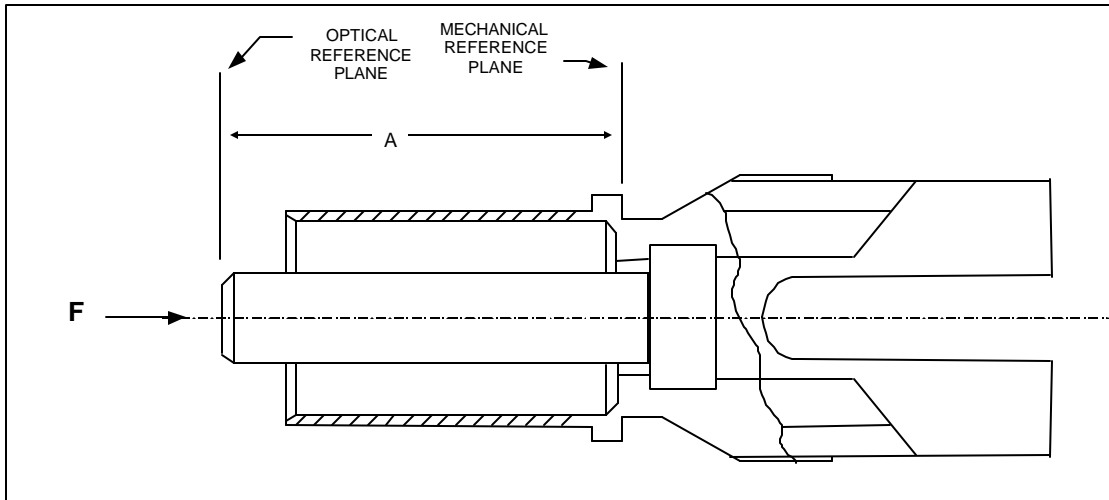

Requirements for ferrule travel and contact force:		
	IF	THEN
1	$F = 0$	$A \geq 7.15$ mm
2	$A \geq 7.1$ mm	$F \geq 7.8$ N (800 gf)
3	$A \geq 6.9$ mm	$F \geq 11.8$ N (1200 gf)

Note: Dimension A is for finished ends after all polishing has been completed

1.8 – SC Connector Coding (or equivalent)

P	6	2	00	A	-	Z	-	125
Plug	Series	Type	Style	Version		Ferrule		Hole Size
		0-SM 1-xxx 2-MM	00- 1.6, 2.0, 3.0mm 01- 0.9mm			Z-Zirconia		

1.9 – SC Connector Color Coding

Connector	Housing Color	Cable Support Color
SM	Blue	Blue
MM	Beige	White
APC	Green	Green

2.0 – SC Adapter Specification

2.1 – SC Simplex and Duplex Adapter: Iso View

2.1a – SC Duplex Adapter

2.1b – SC Simplex Adapter

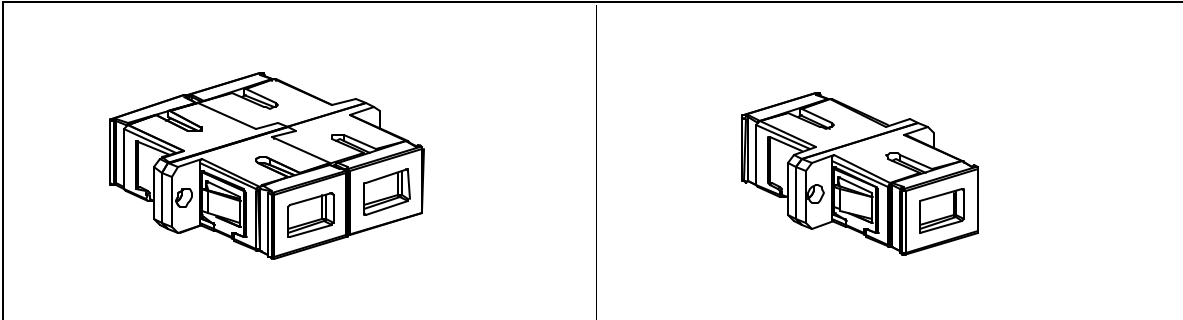

2.2 – SC Adapter Footprint Dimensions

2.2a – SC Duplex Adapter

2.2b – SC Simplex Adapter

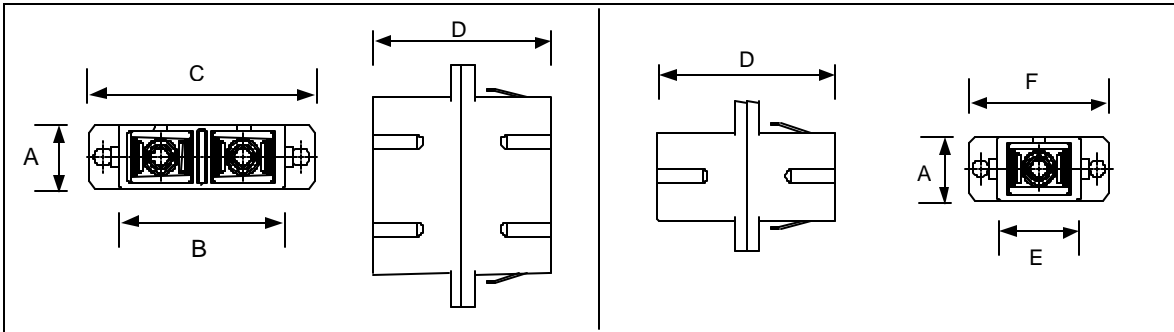

REF.	DIMENSIONS (mm)	
	Minimum	Maximum
A	9.2	9.4
B	-	25.7
C	-	35.2
D	27.5	27.7
E	-	12.8
F	-	22.5

2.3 – Panel Cutout Dimensions for Mounting SC Adapters

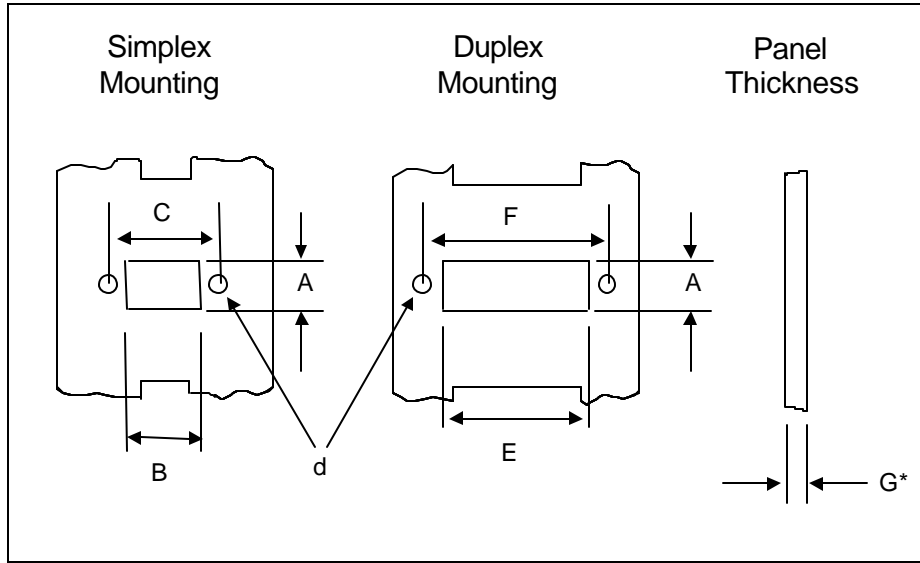

Dimension	Minimum (mm)	Maximum (mm)
A	9.5	10.0
B	13.0	13.5
C	17.9	18.1
E	26.0	26.5
F	30.6	30.8
G*	1.6	1.7
d	2.4	2.6

* Panel thickness "G" applies after surface preparation i.e. painting, etc.

2.4 – SC Adapter Materials

Connector Part	Material	UL 94 Rating	Oxygen Index
Adapter Housing	Engineering Plastics	V-0	28 - 35
Latch Insert	Engineering Plastics	V-0	46.5
Retaining Clip	Stainless Steel	-	-
SM Sleeve	Zirconia	-	-
MM Sleeve	Phosphor Bronze	-	-

2.5 – SC Adapter Illustrations

2.5a – SC Simplex Adapter

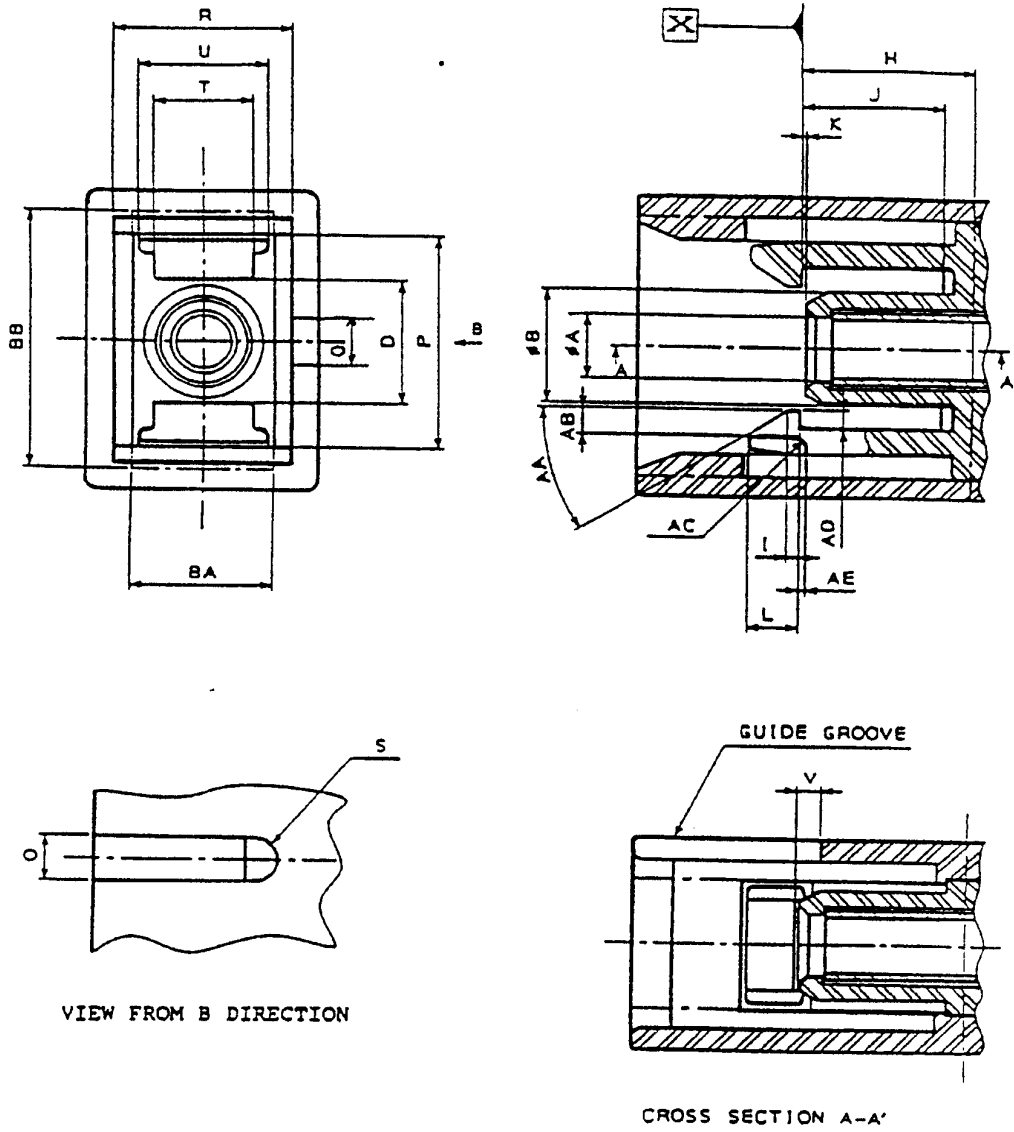

2.5b – SC Duplex Adapter

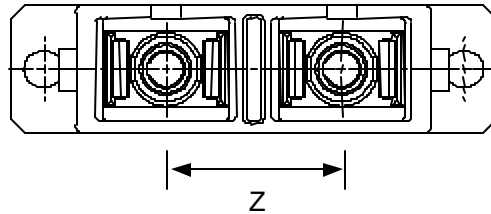

2.5c – SC Adapter Specifications for Intermateability

Ref.	Dimensions (mm)		Notes
	Minimum	Maximum	
A			diameter, 1
B	4.69	4.79	diameter
D	4.9	5.5	
H	6.9	7.1	
I	0.4	0.8	
J	5.51	5.9	
K	0.06	1	
L	1.9	2.1	
O	2.0	2.2	2
P	9.0	9.1	
R	7.4	7.5	
S	1.0	1.1	
T	3.8	4.04	
U	5.0	5.3	
V	0.6	1.6	
AA	27	33	degree
AB	0.8	1.0	
AC	0.4	0.6	
AD	0.7	0.8	
AE	0.4	0.6	
BA	5.4	5.6	
BB	10.8	11.2	
Z	12.7		

Notes:

1. The connector alignment feature is a zirconia ceramic resilient sleeve, which is free to move in the adapter. Alternative materials may be used for the sleeve that have directly compatible materials properties with zirconia. The gauge retention force shall be measured with 2 gauge pins, each inserted to the middle of the alignment feature. The gauge retention force shall be from 2,9 N to 5,9 N, for the extraction of one gauge.
2. The position of the two slots "O" shall lie on the same axis.
3. Mechanical Reference Plane

2.6 – SC Adapter Coding Scheme

C	6	2	0	0	A	-	4
 Adapter	 Series	 Type	 Style		 Sleeve		 Ports
		0-MM 1-SM 2-APC	6-SC to SC 7-SC to ST		A-Zirconia B-Metal		5-Simplex 4-Duplex
					Sleeve 0-Zirconia 1-Metal		

2.7 – SC Adapter Color Coding

Adapter	Housing Color
SM	Blue
MM	Beige
APC	Green

3.0 –Modular Adapters and Attenuators Universal Build-out (UBO)

3.1 – Modular Adapter System (UBO): Exploded View

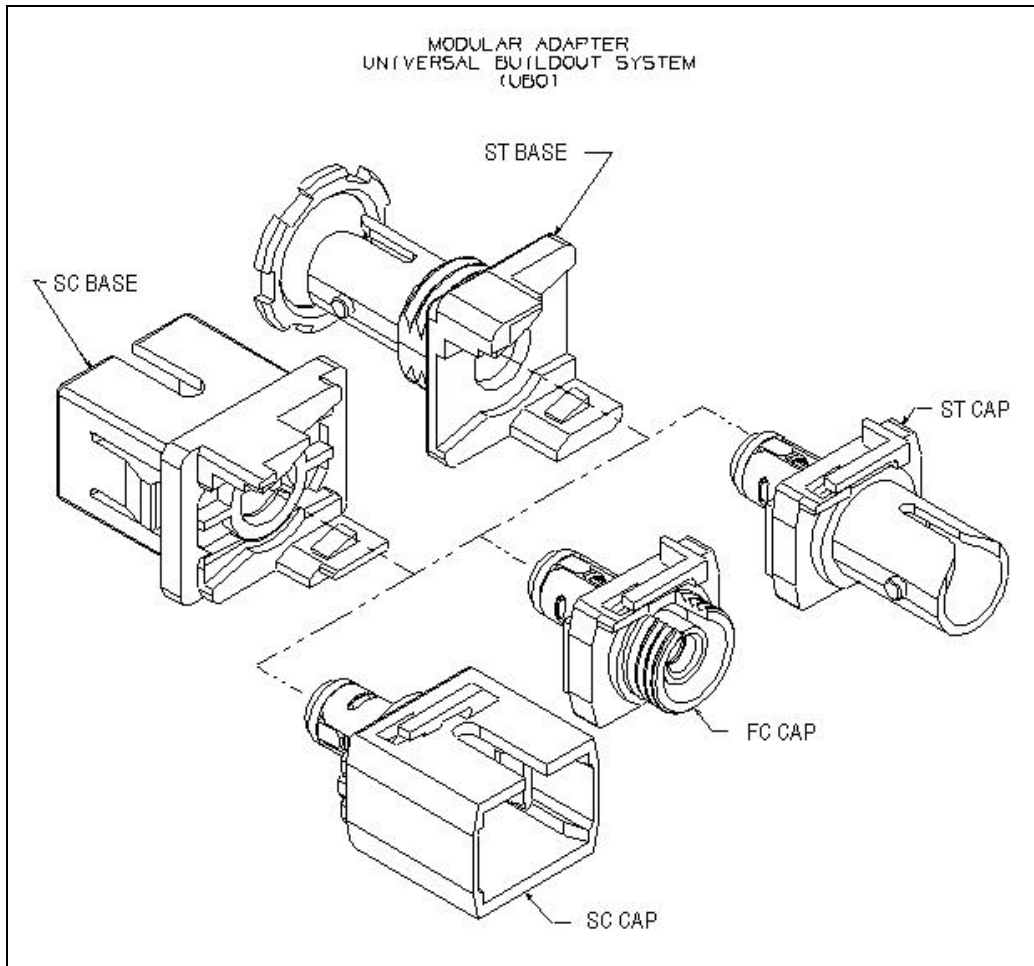

The Modular Adapter System, consisting of a “base”, formally known as a “block”, and a “cap”, formally known as a “build-out”, acts as a split adapter that allows you to standardize your equipment design around one industry connector style, while your customer has the flexibility to choose the connector style that best fit their requirements. With the Modular Adapter System you can easily install attenuators to balance the power output from the transmitter and the system includes two interchangeable components: attenuators and standard caps.

For singlemode, single-fiber connections, the SC, ST and FC are currently the most popular 2.5 mm connectors in the communications industry. They are all based on 2.5mm alignment ferrules, usually made of ceramic materials. The size commonality, along with corresponding alignment sleeves, facilitates the mating of these otherwise different connectors. The above picture depicts a few of OFS Fitel’s Modular Adapter System components that permit mix-or-match interconnections.

3.2 – Modular Adapter SC “

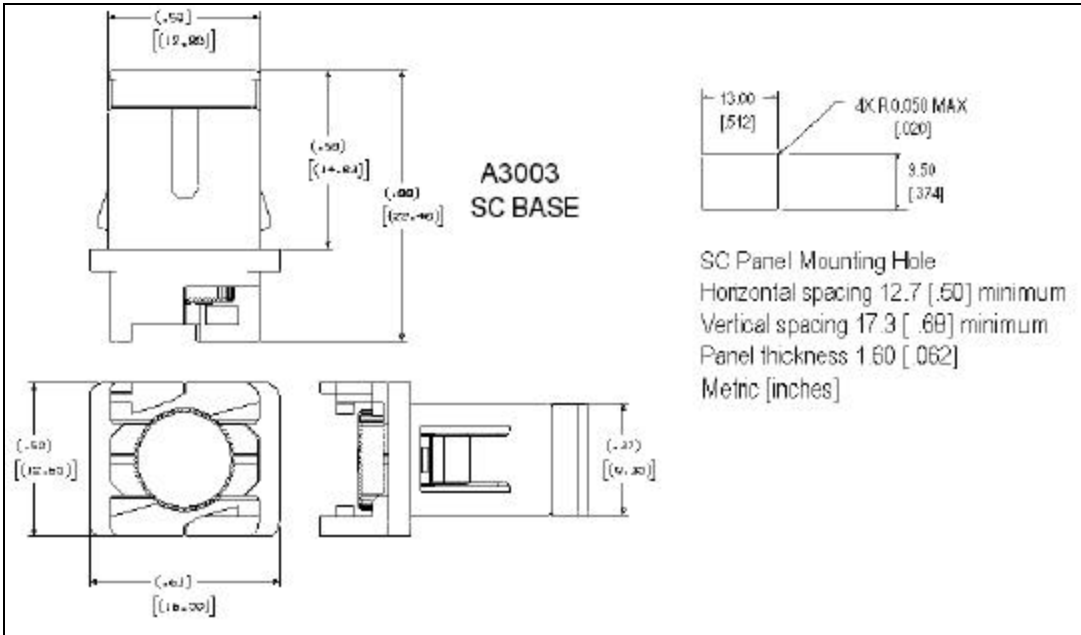

3.3 – Modular Adapter ST “Base” Footprint

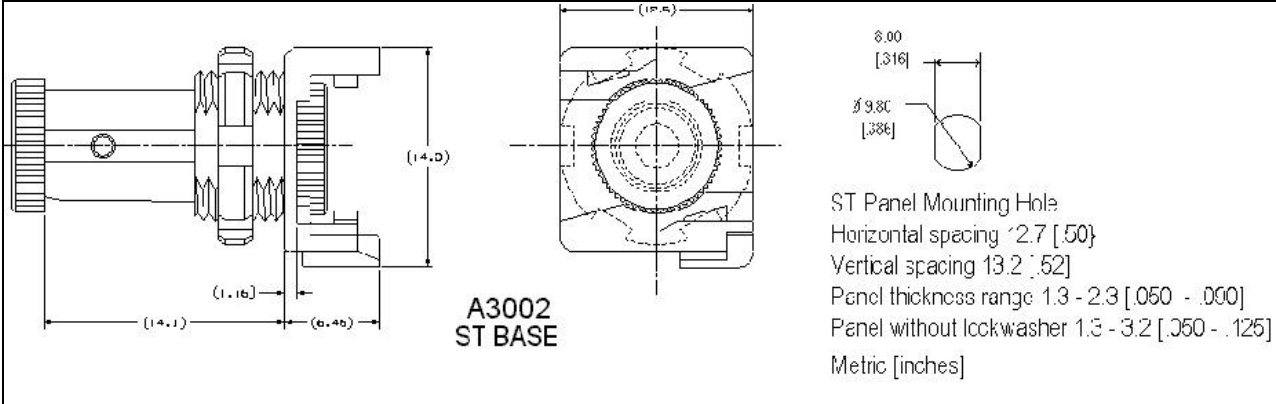

3.4 – Modular Adapter SC “Cap” Footprint

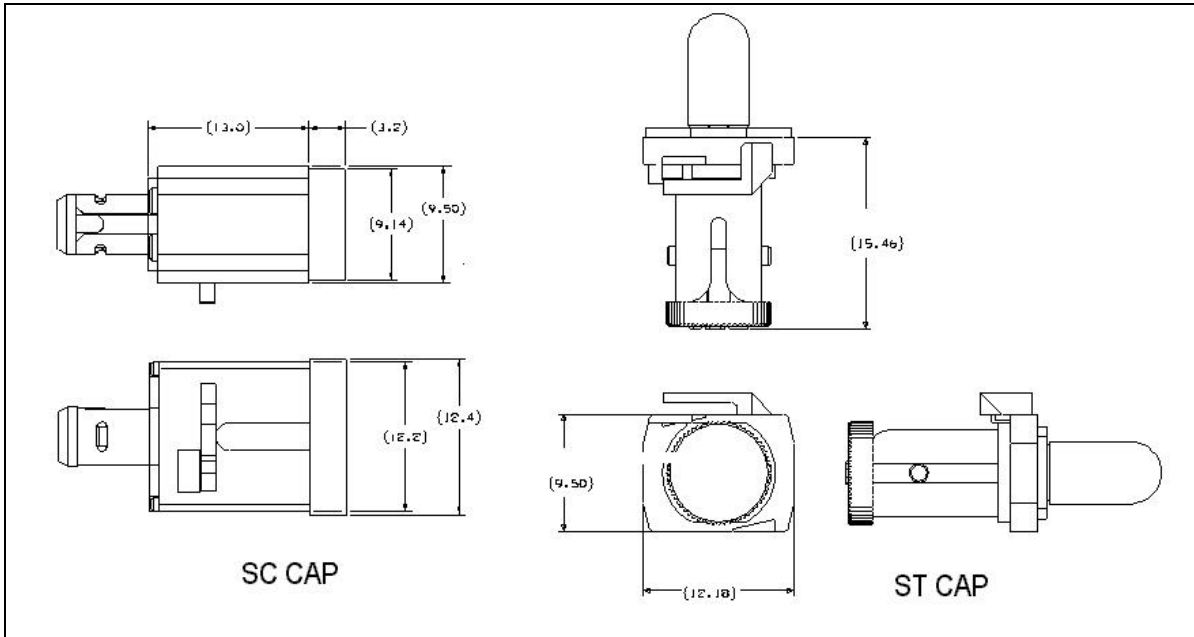

3.5 – Modular Adapter and Attenuator System Materials and Specifications

Connector Part	Material	UL 94 Rating	Oxygen Index
Attenuator Cap	Engineering Plastic	V-0	48
Base	Engineering Plastic	V-0	48
Attenuator Element	Optical Plastic	H.B	T.B.D
Attenuator Sleeve	Zirconia	-	-

Specifications:	Units	Value
Physical		SC Split Adapter Type
Base Color		SC = Blue ST = White
Cap Color		AXXS-x.x = Green AXXM-x.x = Beige/Gray AXXLR-x.x = Light Blue A30x0-x.x = Yellow
Transmission		Singlemode
Nominal Attenuation @ 1550 nm and 0 dBm	dB	See table for each type
Attenuation Tolerance @ 1550 nm and 0 dBm	dB	See table for each type
Maximum Spectral Attenuation Variation (1300 to 1620 nm)	dB	See section 3.12
Maximum Attenuation Variation Due to Incident Power	dB	See section 3.13
Maximum Incident Optical Power Handling Capability	dBm	25
Reflectance	dB	See note below table for each type
Operating Temperature	°C	-40 to 75
Matings over Life		200

3.6 – Modular Adapter “Base” Coding Scheme

Product Code	Order Comcode	Description	Color	Used With
A3002	106709140	ST Universal Base	White	All SC, ST & FC Universal Build-out Caps
A3003	106750763	SC Universal Base	Blue	

3.7 – Modular Adapter “Cap” Coding Scheme

A	SC	S	-	3.0
<i>Attenuator</i>	<i>Connector Type</i>	<i>Style</i>		<i>Attenuation</i>
	ST – ST Cap SC – SC Cap FC – FC Cap	S – Singlemode M – Multimode receive Singlemode launch LR – Low Reflectance		This number represents the Attenuation Value. 0 – represents 0 attenuation

3.8 – ASCS Series Modular Attenuator “Caps” Attenuation Levels and Performance

All numbers apply for 1550 nm and 0 dBm signals
(These attenuator Caps are Green)

PRODUCT CODE	ORDER COMCODE	NOMINAL LOSS (dB)	TYPICAL STANDARD DEVIATION IN LOSS (dB)	NOMINAL LOSS TOLERANCE +/- (dB)
ASCS1.0	108538760	1.3	0.08	0.25
ASCS1.5	109020271	1.5	0.08	0.25
ASCS2.0	108538778	2.0	0.08	0.25
ASCS2.5	109020214	2.5	0.08	0.25
ASCS3.0	108314469	3.0	0.08	0.25
ASCS3.5	108314477	3.5	0.08	0.25
ASCS4.0	108314485	4.0	0.08	0.25
ASCS4.5	108314493	4.5	0.08	0.25
ASCS5.0	108314501	5.0	0.08	0.25
ASCS5.5	108314519	5.5	0.08	0.25
ASCS6.0	108314527	6.0	0.08	0.25
ASCS6.5	108314535	6.5	0.08	0.25
ASCS7.0	108314543	7.0	0.08	0.25
ASCS7.5	108314550	7.5	0.08	0.25
ASCS8.0	108314568	8.0	0.08	0.25
ASCS8.5	108314576	8.5	0.08	0.25
ASCS9.0	108314584	9.0	0.08	0.25
ASCS9.5	108314592	9.5	0.08	0.25

ASCS10	108314600	10.0	0.08	0.25
ASCS11	108440496	11.0	0.17	0.50
ASCS12	108440504	12.0	0.17	0.50
ASCS13	108440512	13.0	0.17	0.50
ASCS14	108440520	14.0	0.17	0.50
ASCS15	108440538	15.0	0.17	0.50
ASCS16	108440546	16.0	0.33	1.00
ASCS18	108440553	18.0	0.33	1.00
ASCS20	108440561	20.0	0.67	2.00
ASCS10	108314600	10.0	0.08	0.25
ASCS11	108440496	11.0	0.17	0.50
ASCS12	108440504	12.0	0.17	0.50
ASCS13	108440512	13.0	0.17	0.50
ASCS14	108440520	14.0	0.17	0.50
ASCS15	108440538	15.0	0.17	0.50
ASCS16	108440546	16.0	0.33	1.00
ASCS18	108440553	18.0	0.33	1.00
ASCS20	108440561	20.0	0.67	2.00
ASTS1.0	108572199	1.3	0.08	0.25
ASTS1.5	109020297	1.5	0.08	0.25
ASTS2.0	108572207	2.0	0.08	0.25
ASTS2.5	109020248	2.5	0.08	0.25
ASTS3.0	108053059	3.0	0.08	0.25
ASTS3.5	108053067	3.5	0.08	0.25
ASTS4.0	108053075	4.0	0.08	0.25
ASTS4.5	108053083	4.5	0.08	0.25
ASTS5.0	108053091	5.0	0.08	0.25
ASTS5.5	108053109	5.5	0.08	0.25
ASTS6.0	108053117	6.0	0.08	0.25
ASTS6.5	108053125	6.5	0.08	0.25
ASTS7.0	108053133	7.0	0.08	0.25
ASTS7.5	108053141	7.5	0.08	0.25
ASTS8.0	108053158	8.0	0.08	0.25
ASTS8.5	108053166	8.5	0.08	0.25
ASTS9.0	108053174	9.0	0.08	0.25
ASTS9.5	108053182	9.5	0.08	0.25
ASTS10	108053190	10.0	0.08	0.25
ASTS10.5	108221359	10.5	0.08	0.50
ASTS11	108053208	11.0	0.08	0.50
ASTS11.5	108221367	11.5	0.08	0.50
ASTS12	108053216	12.0	0.08	0.50
ASTS12.5	108221375	12.5	0.08	0.50
ASTS13	108053224	13.0	0.08	0.50
ASTS13.5	108221383	13.5	0.08	0.50
ASTS14	108053232	14.0	0.08	0.50
ASTS14.5	108221391	14.5	0.08	0.50
ASTS15	108053240	15.0	0.17	0.50

ASTS16	108053257	16.0	0.33	1.00
ASTS18	108053265	18.0	0.33	1.00
ASTS20	108053273	20.0	0.67	2.00
AFCS1.0	108385493	1.3	0.08	0.25
AFCS1.5	109020255	1.5	0.08	0.25
AFCS2.0	108385501	2.0	0.08	0.25
AFCS2.5	109020230	2.5	0.08	0.25
AFCS3.0	108107053	3.0	0.08	0.25
AFCS3.5	108107061	3.5	0.08	0.25
AFCS4.0	108107079	4.0	0.08	0.25
AFCS4.5	108107087	4.5	0.08	0.25
AFCS5.0	108107095	5.0	0.08	0.25
AFCS5.5	108107103	5.5	0.08	0.25
AFCS6.0	108107111	6.0	0.08	0.25
AFCS6.5	108107129	6.5	0.08	0.25
AFCS7.0	108107137	7.0	0.08	0.25
AFCS7.5	108107145	7.5	0.08	0.25
AFCS8.0	108107152	8.0	0.08	0.25
AFCS8.5	108107160	8.5	0.08	0.25
AFCS9.0	108107178	9.0	0.08	0.25
AFCS9.5	108107186	9.5	0.08	0.25
AFCS10	108107194	10.0	0.08	0.25
AFCS10.5	108229097	10.5	0.08	0.50
AFCS11	108107202	11.0	0.08	0.50
AFCS11.5	108229105	11.5	0.08	0.50
AFCS12	108107210	12.0	0.08	0.50
AFCS12.5	108229113	12.5	0.08	0.50
AFCS13	108107228	13.0	0.08	0.50
AFCS13.5	108229139	13.5	0.08	0.50
AFCS14	108107236	14.0	0.08	0.50
AFCS14.5	108229147	14.5	0.08	0.50
AFCS15	108107244	14.5	0.08	0.50
AFCS16	108107251	16.0	0.33	1.00
AFCS18	108107269	18.0	0.33	1.00
AFCS20	108107277	20.0	0.67	2.00

Maximum Reflectance is -30dB Fiber Type is Singlemode
The caps are laser marked with the nominal attenuation (dB)

3.9 – ASCM Series Modular Attenuator “Caps” Attenuation Levels and Performance

(These attenuator Caps are Beige/Gray)

PRODUCT CODE	ORDER COMCODE	NOMINAL LOSS (dB) @ 1550 nm	NOMINAL LOSS TOLERANCE +/- (dB) @ 1550 nm	NOMINAL LOSS TOLERANCE +/- (dB) @ 1310 nm
ASCM5	108440579	5.0	1.00	1.00
ASCM7	108440587	7.0	1.00	1.00
ASCM10	108440595	10.0	1.50	1.50
ASCM12	108440603	12.0	1.80	1.80
ASCM15	108440611	15.0	2.25	2.25
ASCM17	108440629	17.0	2.50	2.50
ASCM20	108440637	20.0	3.00	3.00
ASTM5	108052960	5.0	1.00	1.00
ASTM7	108052986	7.0	1.00	1.00
ASTM10	108052994	10.0	1.50	1.50
ASTM12	108053000	12.0	1.80	1.80
ASTM15	108053018	15.0	2.25	2.25
ASTM17	108053034	17.0	2.50	2.50
ASTM20	108053042	20.0	3.00	3.00
AFCM5	108107285	5.0	1.00	1.00
AFCM7	108107293	7.0	1.00	1.00
AFCM10	108107301	10.0	1.50	1.50
AFCM12	108107319	12.0	1.80	1.80
AFCM15	108107327	15.0	2.25	2.25
AFCM17	108107335	17.0	2.50	2.50
AFCM20	108107343	20.0	3.00	3.00

Maximum Reflectance is -30dB Fiber Type is SM launch, MM receive.

The caps are laser marked with the nominal attenuation (dB)

3.10 – ASCLR Series Modular Attenuator “Caps” Attenuation Levels and Performance

(These attenuator Caps are Light Blue)

PRODUCT CODE	ORDER COMCODE	NOMINAL LOSS (dB) @ 1550 nm	NOMINAL LOSS TOLERANCE +/- (dB) @ 1550 nm	NOMINAL LOSS TOLERANCE +/- (dB) @ 1310 nm
ASCLR2	108647181	2.0	0.5	0.5
ASCLR3	108647447	3.0	0.5	0.5
ASCLR4	108647454	4.0	0.5	0.7
ASCLR5	108647462	5.0	0.5	1.0
ASCLR7	108647470	7.0	0.5	1.1
ASCLR10	108647488	10.0	0.5	1.5
ASCLR15	108647496	15.0	0.75	2.3
ASCLR20	108647504	20.0	1.0	3.0

Maximum Reflectance is -45dB Fiber Type is Singlemode

The caps are laser marked with the nominal attenuation (dB)

3.11 – A3060N1 Series Modular Attenuator “Caps” Attenuation Levels and Performance

(These attenuator Caps are Yellow)

PRODUCT CODE	ORDER COMCODE	NOMINAL LOSS (dB) @ 1550 nm	NOMINAL LOSS TOLERANCE +/- (dB) @ 1550 nm	NOMINAL LOSS TOLERANCE +/- (dB) @ 1310 nm
A3060A1	107380420	3.0	-	0.5
A3060B1	107406142	5.0	-	1.0
A3060D1	107406159	10.0	-	1.0
A3060F1	107406167	15.0	-	2.0
A3060H1	107406175	20.0	-	2.0
A3060X1	107107732	7.0	-	0.7
A3070A1	107380438	3.0	-	0.5
A3070B1	107406183	5.0	-	1.0
A3070D1	107406191	10.0	-	1.0
A3070F1	107406209	15.0	-	2.0
A3070H1	107406217	20.0	-	2.0
A3070X1	107107740	7.0	-	0.7
A3080A1	107380466	3.0	-	0.5
A3080B1	107406225	5.0	-	1.0
A3080D1	107406233	10.0	-	1.0
A3080F1	107406241	15.0	-	2.0
A3080H1	107406258	20.0	-	2.0
A3080X1	107107757	7.0	-	0.7

Maximum Reflectance is -34dB Fiber Type is Singlemode

The caps are laser marked with the nominal attenuation (dB)

3.12 – Modular Adapter Spectral Flatness

Attenuation increases at lower wavelengths. Attenuation for wavelengths other than 1550 nm is described by the following equations:

For $\lambda < 1550$ nm

$$L_S = A (1 + 3.88 \times 10^{-4} (1550 - \lambda))$$

For $\lambda > 1550$ nm

$$L_S = A (1 - 3.88 \times 10^{-4} (\lambda - 1550))$$

L_S = Predicted loss of a randomly selected attenuator in dB

A = Nominal Attenuation value in dB at 1550 nm and 0 dBm

λ = Wavelength in nm

3.13 – Modular Adapter Power Divergence

Below 10 dBm the attenuation is not affected by the power level.

At 10dBm and above the loss depends on Power and Attenuation level and can be described by the following equation:

$$L = A + 0.213 - 0.0143 P + 0.000806 P^2 + 0.0826 A - 0.00439 A^2 + 0.000279 A^3 - 0.00823 AP + 0.000358 AP^2$$

L = Predicted loss of a randomly selected unit in dB

A = Nominal Attenuation value of the unit

P = Power in dBm

This dependence is shown in the plot below.

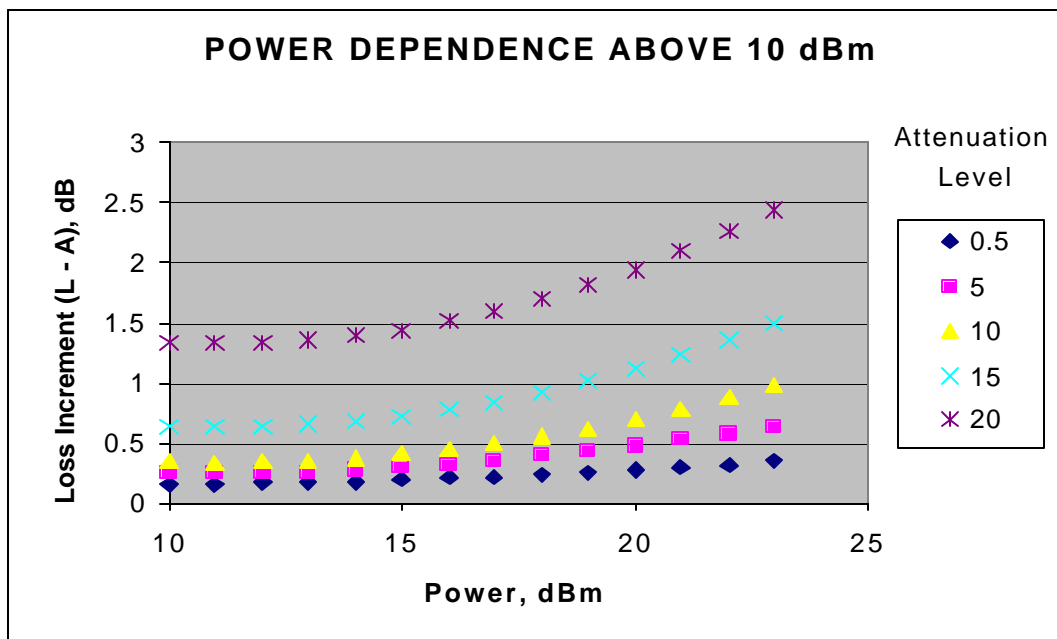

3.14 – Modular Adapter Compliance to GR-910 and GR-326

Compliance to Telcordia GR-910

Split adapter attenuators, when assembled with either the A3002 ST Base or A3003 SC base comply with all the requirements of Telcordia GR-910 except the maximum reflection is greater than -40 dB.

Compliance to Telcordia GR-326

0 dB Caps assembled with the A3002 ST or A3003 SC base comply with the requirements of GR-326 except the transmission under side loads exceeds the maximum change in loss at 4.4 pounds.

4.0 – SC Build-On Attenuators

4.1 – Build-On Attenuator System Application

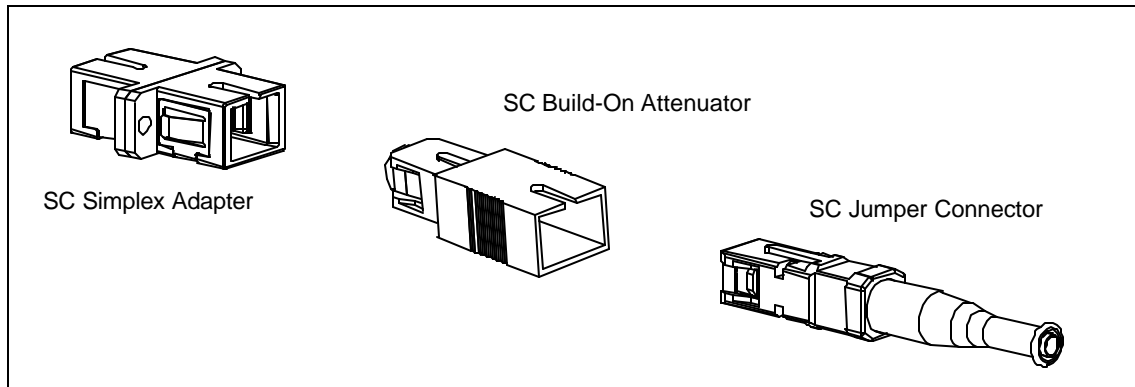

AllWave ADVANTAGE™ attenuators can enhance networks where you need attenuation. OFS Fitel's standard-polish attenuators have low reflection to meet stringent system requirements and are backward compatible with existing transmission equipment. These AllWave attenuators are designed to provide flat spectral loss across the full spectrum, which allows the attenuators to operate in the entire wavelength region from 1280 nm to 1625 nm.

These attenuators can be placed either on the receive side of the LGX or directly on the active equipment. These “build-on” style attenuators are a combination of an SC connector on one end, and an SC adapter on the other end. This allows the attenuator to be placed in-line between an adapter and a jumper or pigtail.

The AllWave Attenuator achieves the desired attenuation by using a specific grade of high-loss fiber epoxied into a ferrule that is assembled into the attenuator. By using a fiber-ferrule technology, return loss measurements of 50* dB or better can be achieved. The end-face geometry of both the inside & outside ferrule surfaces meet the same requirements and specifications found in Sections 6.7 and 6.8 for Polished Ferrule End-Face Geometry.

*Note: for APC, return loss is >60 dB

4.2 – Build-On Attenuator Footprint Illustration

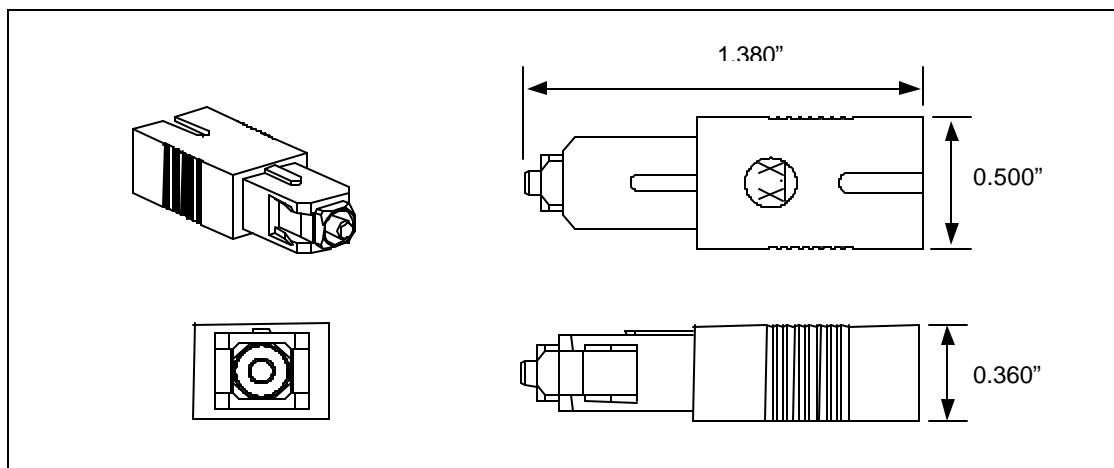

4.3 – Build-On Attenuator Materials and Specifications

Connector Part	Material	UL 94 Rating	Oxygen Index
Attenuator	Engineering Plastic	??	??
Ferrule	Ceramic	-	-
Barrel	Metal	-	-

Specifications:	Units	Value
Physical		SC "In-Line" Adapter Type
Color		Metallic silver
Transmission		Singlemode
Nominal Attenuation @ 1550 nm and 0 dBm	dB	See Table for each type
Attenuation Tolerance @ 1550 nm and 0 dBm	dB	See Table for each type
Maximum Spectral Attenuation Variation (1300 to 1620 nm)	dB	?
Maximum Attenuation Variation Due to Incident Power	dB	?
Maximum Incident Optical Power Handling Capability	dBm	25 (?)
Reflectance	dB	See table for each type
Operating Temperature	°C	-40 to 75
Matings over Life		??

4.4 – Build-On Attenuator Coding Scheme

A	B	SC	S	-	3.0
 <i>Attenuator</i>	 <i>Type</i>	 <i>Connector Type</i>	 <i>Style</i>		 <i>Attenuation</i>
	B – Build-On	SC – SC	S – PC A – APC		This number represents the attenuation value.

**4.5 – ABSCS Series Build-on Attenuator
Attenuation Levels and Performance (PC polish)**

All numbers apply for 1550 nm and 0 dBm signals

PRODUCT CODE	ORDER COMCODE	NOMINAL LOSS (dB)	MINIMUM RETURN LOSS (dB)	TYPICAL STANDARD DEVIATION	NOMINAL LOSS TOLERANCE +/- (dB)
ABSCS-0.5	109177634	0.5	50	-	0.25
ABSCS-1.0	109177683	1.0	50	-	0.25
ABSCS-1.5	109177758	1.5	50	-	0.25
ABSCS-2.0	109177808	2.0	50	-	0.25
ABSCS-2.5	109177857	2.5	50	-	0.25
ABSCS-3.0	109177642	3.0	50	-	0.25
ABSCS-3.5	109177659	3.5	50	-	0.25
ABSCS-4.0	109177667	4.0	50	-	0.25
ABSCS-4.5	109177675	4.5	50	-	0.25
ABSCS-5.0	108617549	5.0	50	-	0.5
ABSCS-6.0	109177709	6.0	50	-	0.5
ABSCS-7.0	109177717	7.0	50	-	0.5
ABSCS-8.0	109177733	8.0	50	-	0.5
ABSCS-9.0	109177741	9.0	50	-	0.5
ABSCS-10.0	108617556	10.0	50	-	0.5
ABSCS-11.0	109177766	11.0	50	-	0.5
ABSCS-12.0	109177774	12.0	50	-	0.5
ABSCS-13.0	109177782	13.0	50	-	0.5
ABSCS-14.0	109177790	14.0	50	-	0.5
ABSCS-15.0	108618554	15.0	50	-	0.5
ABSCS-16.0	109177816	16.0	50	-	0.5
ABSCS-17.0	109177824	17.0	50	-	0.5
ABSCS-18.0	109177832	18.0	50	-	0.5
ABSCS-19.0	109177840	19.0	50	-	0.5
ABSCS-20.0	108618562	20.0	50	-	1.0
ABSCS-25.0	109177865	25.0	50	-	2.0

**4.6 – ABSCA Series Build-on Attenuator
Attenuation Levels and Performance (APC Polish)**

All numbers apply for 1550 nm and 0 dBm signals

PRODUCT CODE	ORDER COMCODE	NOMINAL LOSS (dB)	MINIMUM RETURN LOSS (dB)	TYPICAL STANDARD DEVIATION	NOMINAL LOSS TOLERANCE +/- (dB)
ABSCA-03.0	108618570	3.0	60	-	0.15
ABSCA-05.0	108618588	5.0	60	-	0.15
ABSCA-07.0	108618596	7.0	60	-	0.15
ABSCA-10.0	108618504	10.0	60	-	0.15
ABSCA-15.0	108618512	15.0	60	-	0.15

ABSCA-20.0	108618520	20.0	60	-	0.15
-------------------	-----------	------	----	---	------

5.0 – SC Terminator Specification

5.1 – SC Terminator Application

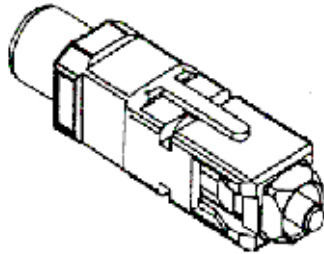

SC Terminator

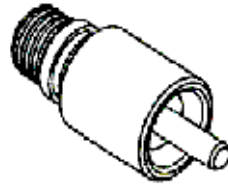

FC Terminator

Terminators are designed to reduce back-reflections typically found on laser-activated, connectorized access points such as those found on splitters, DWDM's or Fiber Distribution Frames (LGX™). With the rapid deployment of high-speed optical multiplexers, the possibility of having an unterminated derived channel or branch increases. Any single fiber connector mated to an adapter or coupling, that is unused, is a source of back-reflection. Back-reflection can be a major cause of bit errors within the system.

Features:

- ?? Engineered Plastic ferrules
- ?? Available in SC, FC, LC and MU
- ?? Up to 20 re-matings
- ?? Operational between 1310 and 1550 nm
- ?? -45 dB reflectance

Benefits:

- ?? Low cost
- ?? Compatible to most connector types
- ?? Effectively removes back-reflectance

5.2 – Terminator Information and Performance

PRODUCT CODE	ORDER COMCODE	DESCRIPTION	REFLECTANCE
LC-T	108 904 368	LC Terminator	<45 dB
LC-T-100	108 897 356	LC Terminator (100 pack)	<45 dB
SC-T	107 796 864	SC Terminator	<45 dB
SC-T-100	107 860 157	SC Terminator (100 pack)	<45 dB
FC-T	107 857 104	FC Terminator	<45 dB
FC-T-100	108 897 380	FC Terminator (100 pack)	<45 dB

6.0 – SC-LC Converter

6.1 – SC-LC Converter Application

The SC-to-LC Converter features an SC connector on the front and a LC adapter on the back. This converter can be used in those applications where customers may have chosen to convert to the LC system (connectors and jumpers) but still has an embedded base of SC adapters in their system.

The converter has been designed to yield an insertion loss of ≈ 0.5 dB, and to prevent Multipath Interference (MPI).

6.2 – SC-LC Converter Footprint Illustration

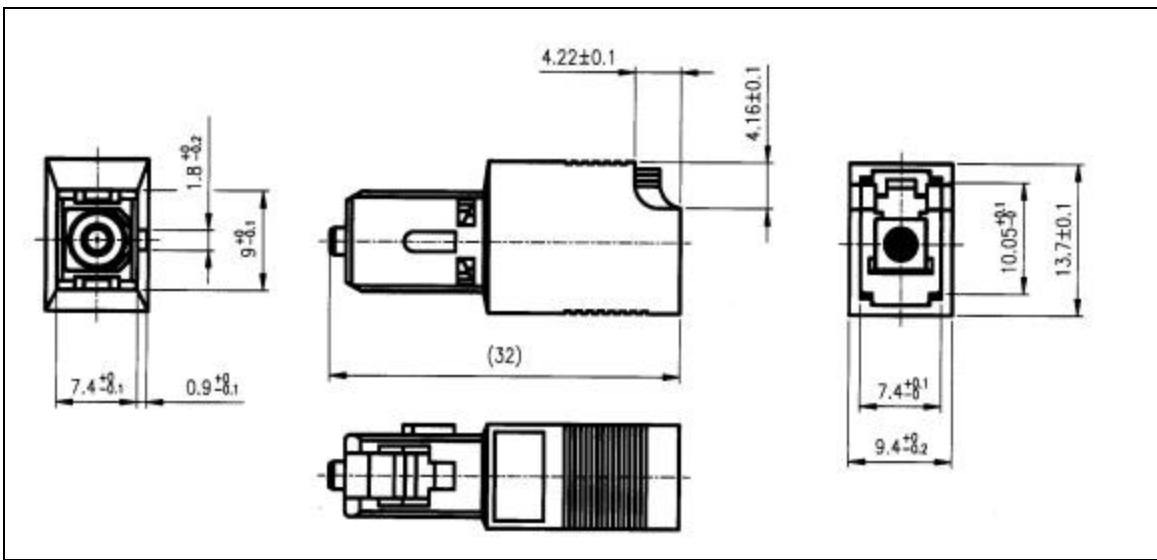

6.3 – SC-LC Converter Information and Performance

PRODUCT CODE	ORDER COMCODE	DESCRIPTION	MAXIMUM INSERTION LOSS (dB)
	109 119 834	SC-LC Converter	0.5

7.0 – SC Jumper Specification

7.1 – SC Simplex Jumper

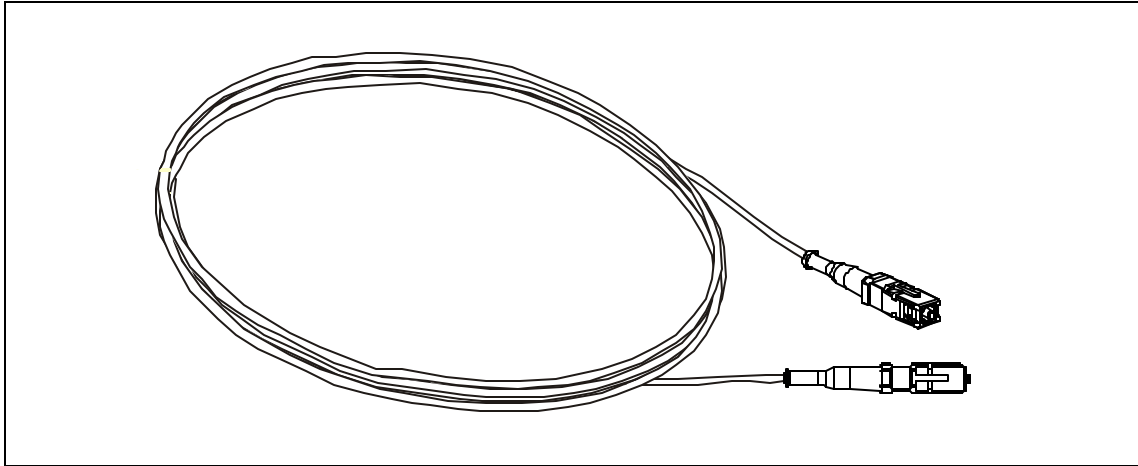

7.2 – SC Simplex Jumper Exploded Assembly

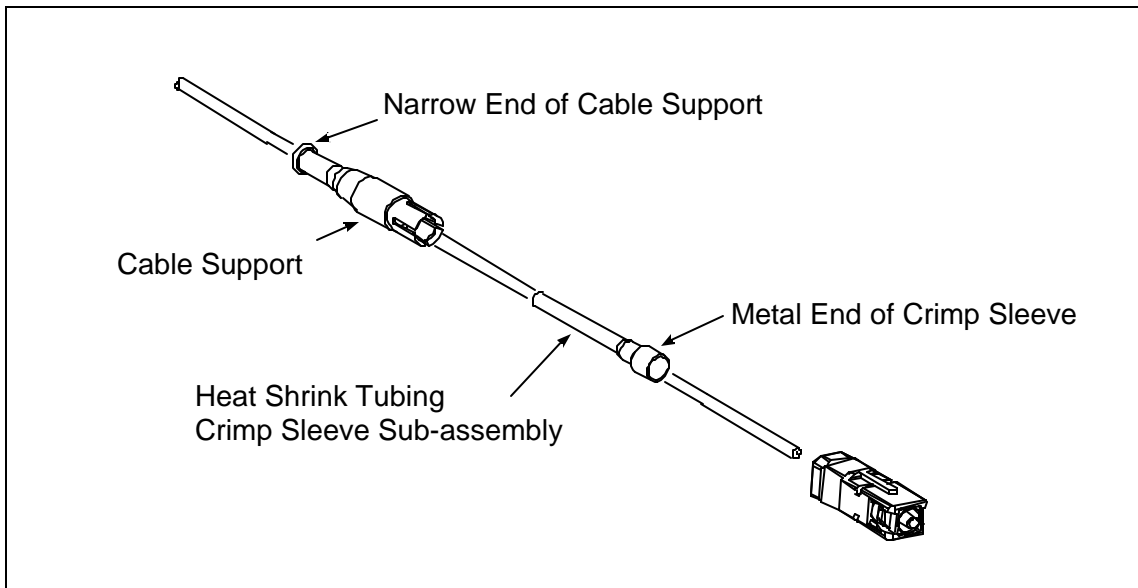

7.3 – SC Duplex Jumper Exploded Assembly

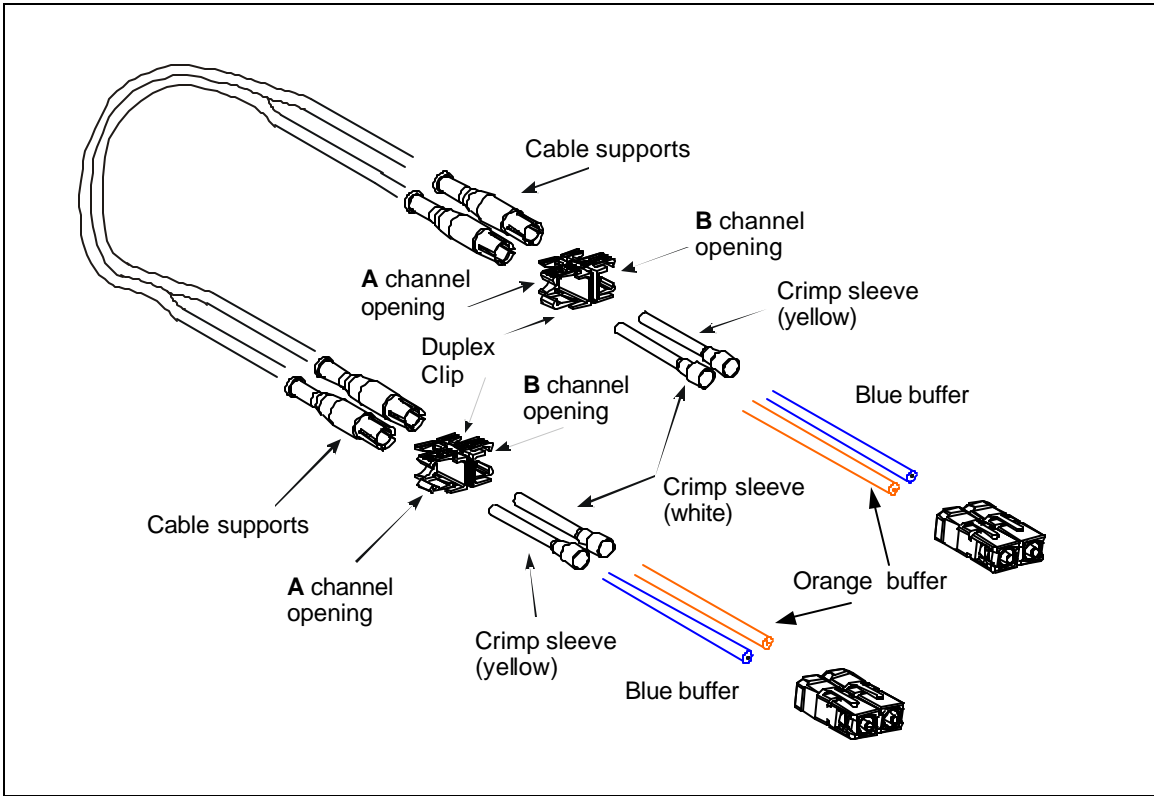

7.4 – SC Duplex MM Jumper as per TIA/EIA

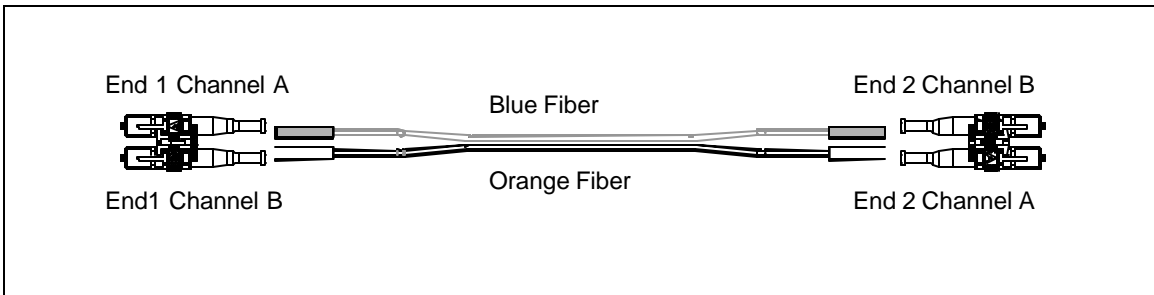

7.5 – SC Jumper/Connector Materials

Connector Part	Material	UL 94 Rating	Oxygen Index
Ferrule	Zirconia	-	-
Barrel	Stainless Steel	-	-
Cable Support Boot	Engineering Plastics	V-0	29
Spring	Stainless Steel	-	-
Plug Frame	Engineering Plastics	V-0	34
Duplex Clip	Engineering Plastics	V-0	35
Grip	Engineering Plastics	V-0	34
Buffer Boot	Engineering Plastics	V-0	29
Cable Retention Member	Ni-plated Brass	-	-
Crimp Sleeve	Anodized Aluminum	-	-
Sheath Tube	Ni-plated Brass	-	-
1.6mm Minicord		UL 1666	
Jacket	PVC		
Buffer	Nylon		
Strength Material	Aramid Yarn		

7.6 – Cordage Technical Specifications

Multimode Fiber, Core/Cladding	62.5/125 microns
Singlemode Fiber, Core/Cladding	8.3/125 microns
Fiber Coating	250 micron
Buffer Diameter	0.9 mm
Jacket Diameter, Minicord	1.6 mm
Standard Cordage	3.0 mm
Fiber Proof Test	100 KPSIs (689 N/mm ²)
Cordage Proof Test, Minicord	20 lb. (89 N)
Standard Cordage	30 lb. (133 N)

7.7 – SC Singlemode Ferrule Endface Geometry

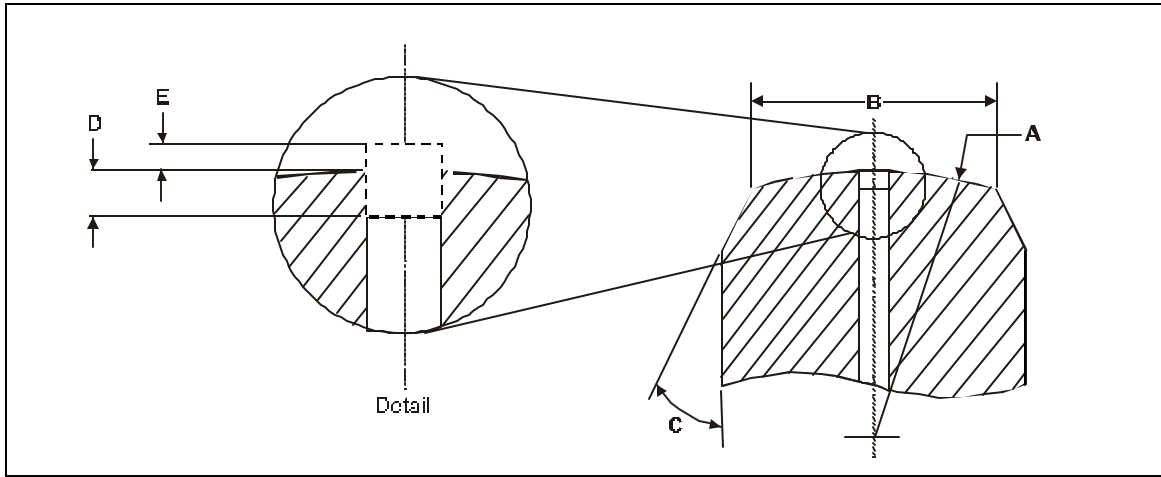

Item	Reference	Minimum	Nominal	Maximum	Dimensions
Radius	A	10		25	mm
Pedestal ²	B	1.75	1.9	2.26	mm
Dome ECC.	—	0	—	0.050	mm
Chamfer	C	25	30	35	degrees
Undercut	D	—	—	See Graph A	nm
Protrusion	E	—	—	50	nm

²Pedestal diameter after polishing.

Note: Dimensions in table below are for reference only and apply after polishing procedures have been completed.

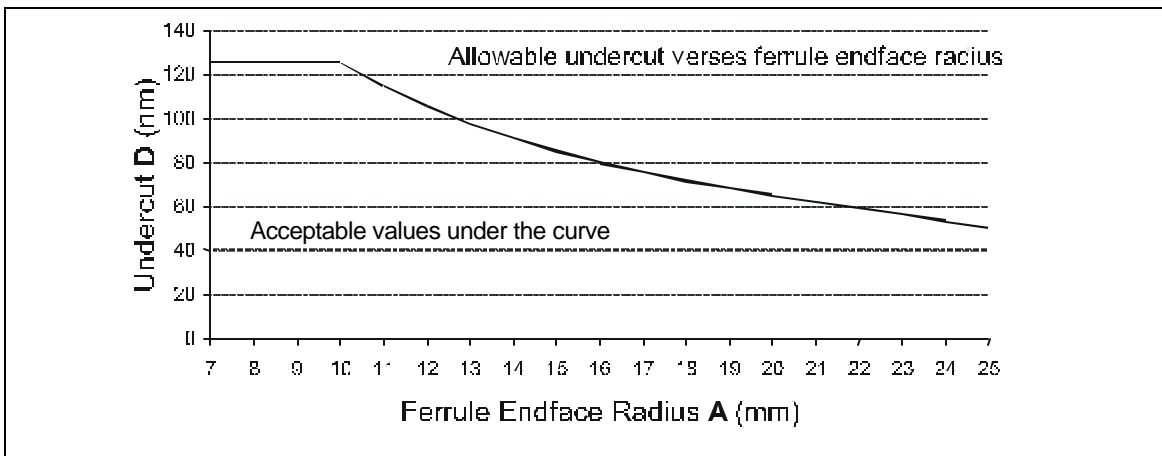

Graph A. Recommended Fiber Undercut

Note: End-face geometry is reference information only (non-critical inspection points). Return Loss and insertion loss are the critical inspection criteria.

7.8 – SC APC Ferrule End-face Geometry

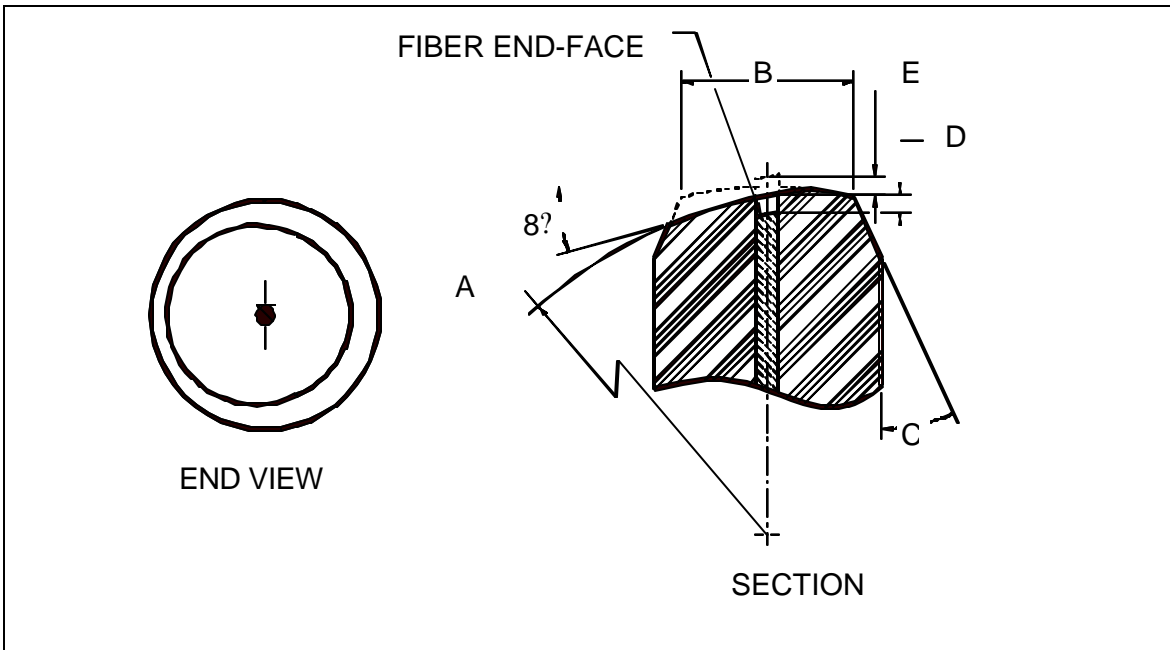

Item	Reference	Minimum	Nominal	Maximum	Dimensions
Radius	A	5	-	12	mm
Pedestal	B	0.8	-	1.7	mm
Dome ECC.	-	0	-	0.050	mm
Chamfer	C	25	-	35	degrees
Undercut	D	-	-	100	nm
Protrusion	E	-	-	100	nm

Note: End-face geometry is reference information only (non-critical inspection points). Return Loss and insertion loss are the critical inspection criteria.

7.9 – SC APC Ferrule/Angle Orientation

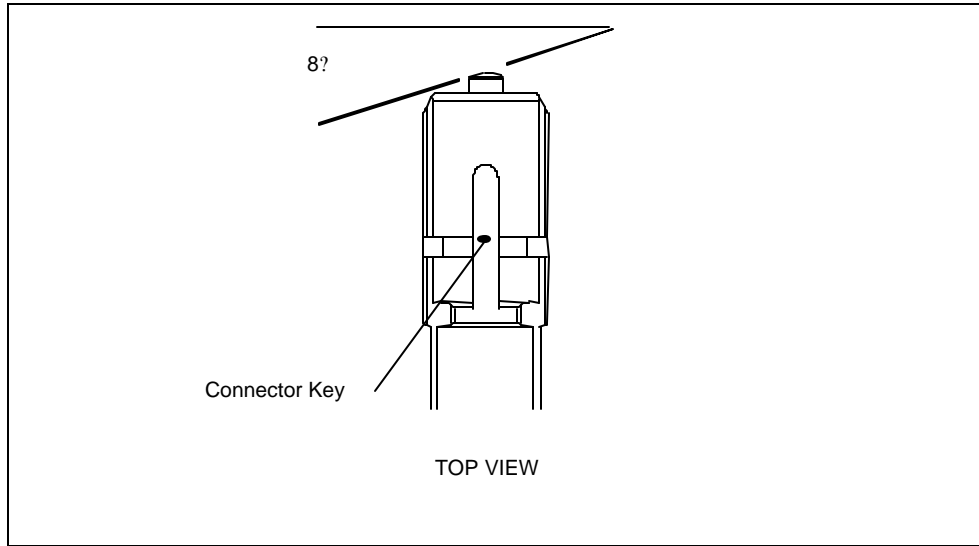

7.10 – SC Factory Made PC Patch Cord – Specifications

Fiber Type	Singlemode PC	APC	Multimode
Loss ¹ : Avg./Std. Dev.	0.15 dB/0.08 dB (Tuned)*	0.25 dB/0.12 dB	0.2 dB/0.1 dB
Loss ¹ : Maximum	0.3 dB ³	0.5 dB	0.5
Return Loss Minimum	55 dB	65 dB	20 dB
Cable Retention ² (1.6mm) (3.0 mm)	20 lbs./29.67 N 30 lbs./44.5 N	20 lbs./89 N 30 lbs./133 N	20 lbs./89 N 30 lbs./133 N
Mating Durability (500 Reconnects) Insertion Loss Change	< 0.2 dB	< 0.2 dB	< 0.2 dB
Temp. Stability (-40 °C to 75 °C) Insertion Loss Change	< 0.3 dB	< 0.3 dB	< 0.3 dB

1. Complete connection concatenated statistics 8.8/125 fiber, 62.5/125 fiber. Dry connection.
2. Values represent axial force on connector with 0° axial pull on cordage. See cordage specification in Section 7.6. Cable dependent to cause permanent light transmission failure. Figures representative of use with OFS Fitel jumper cordage or equivalent.
3. The performance is representative of all SC-PC factory patchcords herein.
 $X_{\max} + 2\sigma = 0.31 \text{ dB}$, $X_{\max} + 3\sigma = 0.39 \text{ dB}$
4. Optical performance is dependant on ferrule endface cleanliness. Cleaning the endface prior to examination or installation is recommended. See Telcordia GR-326_COR, Issue 3, September 1999, Section 4.3 for recommended cleaning procedure.

7.11 – Visual Inspection Criteria for Fiber Optic Connectors with Fiber

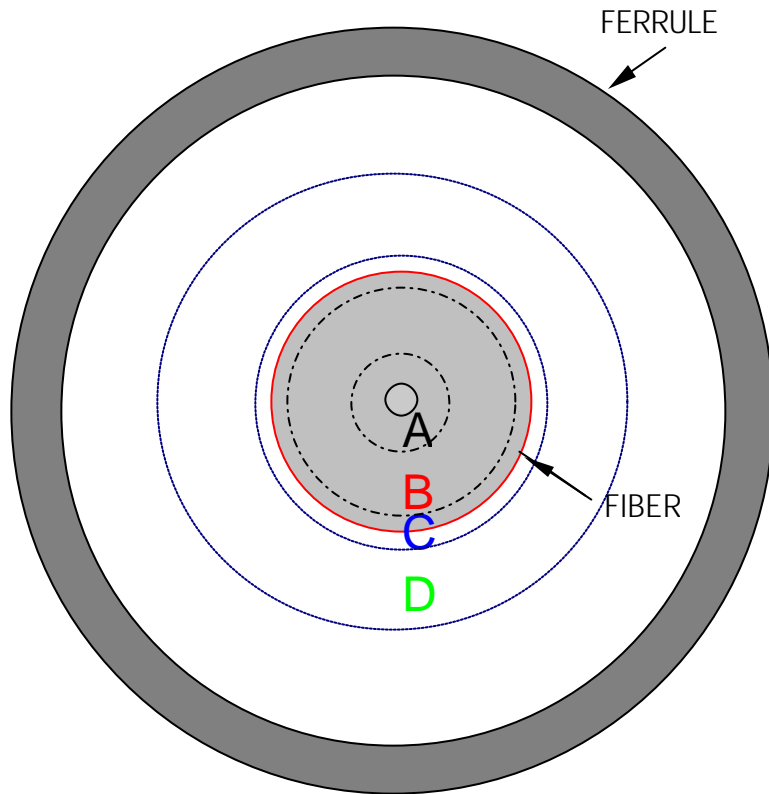

Figure not-to-scale.

Magnification (minimum)	200x
Resolving Power	1 μm
Numerical Aperture	0.3

INSPECTION CRITERIA: SINGLEMODE	
A Core Zone	
Diameter	0 - 25 μm
Scratches (SM)	None
Pits & Chips	None
Contamination	None
Crack	None
Other	
B Cladding Zone	
Diameter	25 - 120 μm
Scratches (SM)	Up to 3 scratches of any length, 1-3 μm width
Pits & Chips	Unlimited (<2 μm dia.)
Contamination	None
Crack	None
C Epoxy Zone	
Diameter	120 - 130 μm
Scratches (SM)	Unlimited
Pits & Chips	Unlimited (<5 μm dia.)
Contamination	No loose particles
D Contact Zone	
Diameter	130 - 250 μm
Scratches (SM)	Unlimited
Pits & Chips	Unlimited
Contamination	No loose particles

INSPECTION CRITERIA: SINGLEMODE_APC same as singlemode above except as noted.	
A Core Zone	
Scratches	Any length > 2 μm width if

Notes:

- For optical performance, see Table 5.10 of Factory Made PC Patch Cord - Specification.
- Proposed measurement method IEC 86B WG4 6130C 3-X dated October 2001.
- Since loose particles may be introduced during the inspection process, cleaning the end-face is recommended prior to insertion into the microscope. Cleaning procedures are found in Section 4.3 of Telcordia GR-326-CORE, Issue 3, September 1999.
- Figure and singlemode Table proposed IEC 86B WG6 Level 2 Specification for polished fiber end faces. Scratches and defects > 1.0 μm are not counted. Dated October 2001, except 2 μm scratch width & pit diameter was 1 μm.
- Outside the 250 μm contact zone there are no requirements for visual inspection since defects found in this region have no influence on the optical performance of PC polished ferrules.

7.12 – SC SM Jumper Tuning Configuration

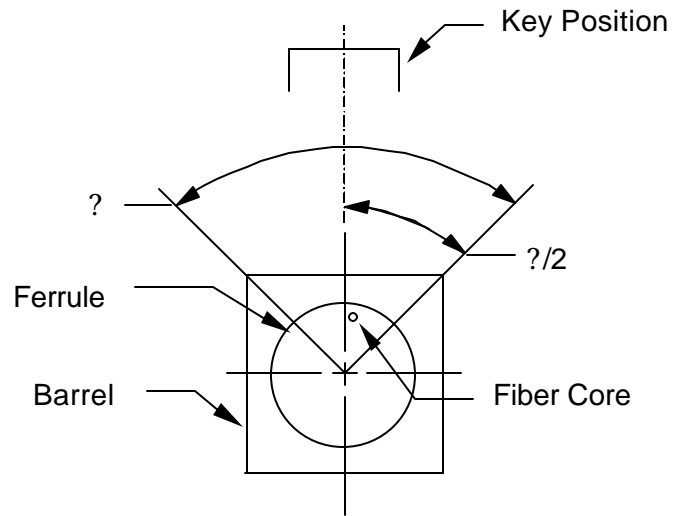

Notes:

If tuning is required to minimize loss, the eccentricity of the fiber core is to be located relative to the connector key within the angle θ as shown.

$\theta \approx 180^\circ$

7.13 – SC Jumpers – Available Configurations

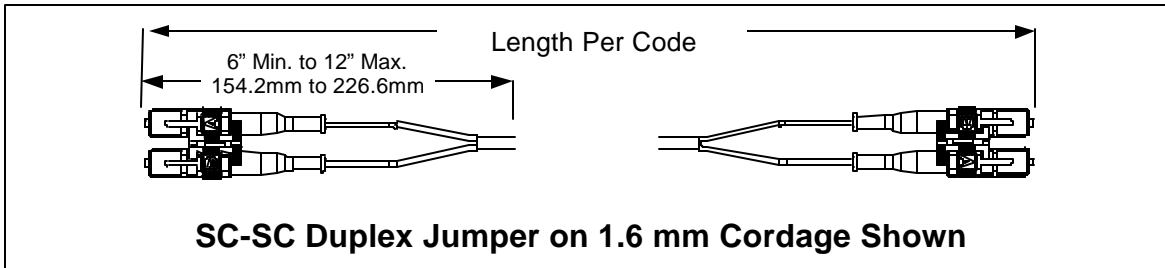

SC-SC	SC-LC	SC-FC	SC-ST
SM & MM	SM & MM	SM & MM	SM & MM
Simplex & Duplex	Simplex & Duplex	Simplex & Duplex	Simplex & Duplex
Available Lengths and Tolerances			
Feet			Meters
4 +0.5/-0			1.2 +0.15/-0
5 +0.5/-0			1.5 +0.15/-0
6 +0.5/-0			1.8 +0.15/-0
8 +0.5/-0			2.4 +0.15/-0
10 +0.5/-0			3.1 +0.15/-0
15 +1/-0			4.6 +0.3/-0
20 +1/-0			6.1 +0.3/-0
25 +1/-0			7.6 +0.3/-0
30 +1/-0			9.2 +0.3/-0
35 +1/-0			10.7 +0.3/-0
40 +1/-0			12.2 +0.3/-0
50 +1/-0			15.2 +0.3/-0
75 +1/-0			22.9 +0.3/-0
100 +1/-0			30.5 +0.3/-0

7.14 – SC Jumper Coding Scheme

M	S	2	SC	-	SC	-	10
<i>Cordage Type</i>	<i>Fiber Type</i>	<i>Jumper Type</i>	<i>Connector Type (end 1)</i>		<i>Connector Type (end 2)</i>		<i>Length (ft)</i>
M - Minicord	S - SM	1-Simplex	SC for SC		SC for SC		
B - SBJ	L - MM (62.5)	2-Duplex	SCA for SC Angled		SCA for SC Angled		
N - Nylon Buffer	W - AllWave™	4-Quad			FC for FC		
F or L – 3.0mm	D - LaserWave™				FCA for FC Angled		
	SR – Red Jacket				D4 for D4		
	SB – Blue Tiger				EP for STII+		
					LC for LC		
					LCA for LC Angled		

7.15 – SC Jumper Color Coding

Jumper	Connector Color	Cordage Color
SM	Blue w/ White Boot	Yellow
SM AllWave	Blue w /White Boot	Violet
MM 62.5 ?m	Beige w/ White Boot	Slate (Gray)
MM LaserWave	Beige w/ White Boot	Aqua
APC	Green w/ Green Boot	Yellow

8.0 – SC Tools, Kits, and Consumables

8.1 – Ordering Information

PRODUCT CODE	ORDER COMCODE	DESCRIPTION
1032J	108 313 685	SC Tool Kit
1032B5	106 705 213	Tool Kit with Oven for Epoxy
1032B6	106 919 012	Tool Kit with International Oven for Epoxy
1032F1	107 149 320	Tool Kit for EZ method
D-182738	106 919 236	Consumables for mounting 100 MM connectors using epoxy
D-182739	106 919 244	Consumables for mounting 100 SM connectors using epoxy
D-182919	106 983 041	Crimp Sleeves for mounting 100 connectors on MiniCord Cable
D-182804	107 148 942	Consumables for mounting 100 MM connectors using EZ
D-182720	107 834 039	Consumables for mounting 100 SM connectors using EZ
1510A	108 237 710	Polishing Fixture
1510B	106 918 998	Crimping Tool
1510C	109 919 004	Curing Fixture
2A1	106 917 263	SC Duplex Connector Clip (bulk pack of 5)