

APPARATUS CODE	LUCENT P/L APPARATUS COMCODE	AVAYA ORDERING COMCODE	LUCENT OFFERING COMCODE
AVLST1U-072/7	109128561	700007289	105335871

NOTES

1. THE GEOMETRY OF THIS PART HAS BEEN CREATED USING UNIGRAPHICS AND IS STORED IN THE ATLANTA UNIGRAPHICS VAULT.
2. SHIP UN-ASSEMBLED IN SUITABLE PROTECTIVE CONTAINER WITHIN UNIT. TO BE FIELD ASSEMBLED PER INSTRUCTION SHEETS AND FIELD REQUIREMENTS.
3. A SHOP PRINTED LABEL WHICH SHOWS CODE, LOCATION, AND DATE OF MANUFACTURE SHALL BE INSTALLED ON INTERIOR SURFACE OF SHELF APPROXIMATELY WHERE SHOWN.
4. INSERT SOUTHCO CAPTIVE SCREW FROM FRONT OF PANEL AND THREAD THE RETAINER ALL THE WAY ON FROM THE REAR. FLATTEN RETAINER WITH SPECIAL TOOL TO SECURE.
5. SHELF LABEL (ITEM 37) IS ATTACHED TO DOOR ASSEMBLY USING HANGERS (ITEM 11) ON DOOR.
6. FOR PACKING, CARTON LABELING AND ADDITIONAL INSTRUCTIONS, REFER TO PL-8001.

ENGR	BA RICHTER	RARITAK
DRAWN	LV LAWRENCE	LVL/RWH
	8-10-01	ISSUE 1

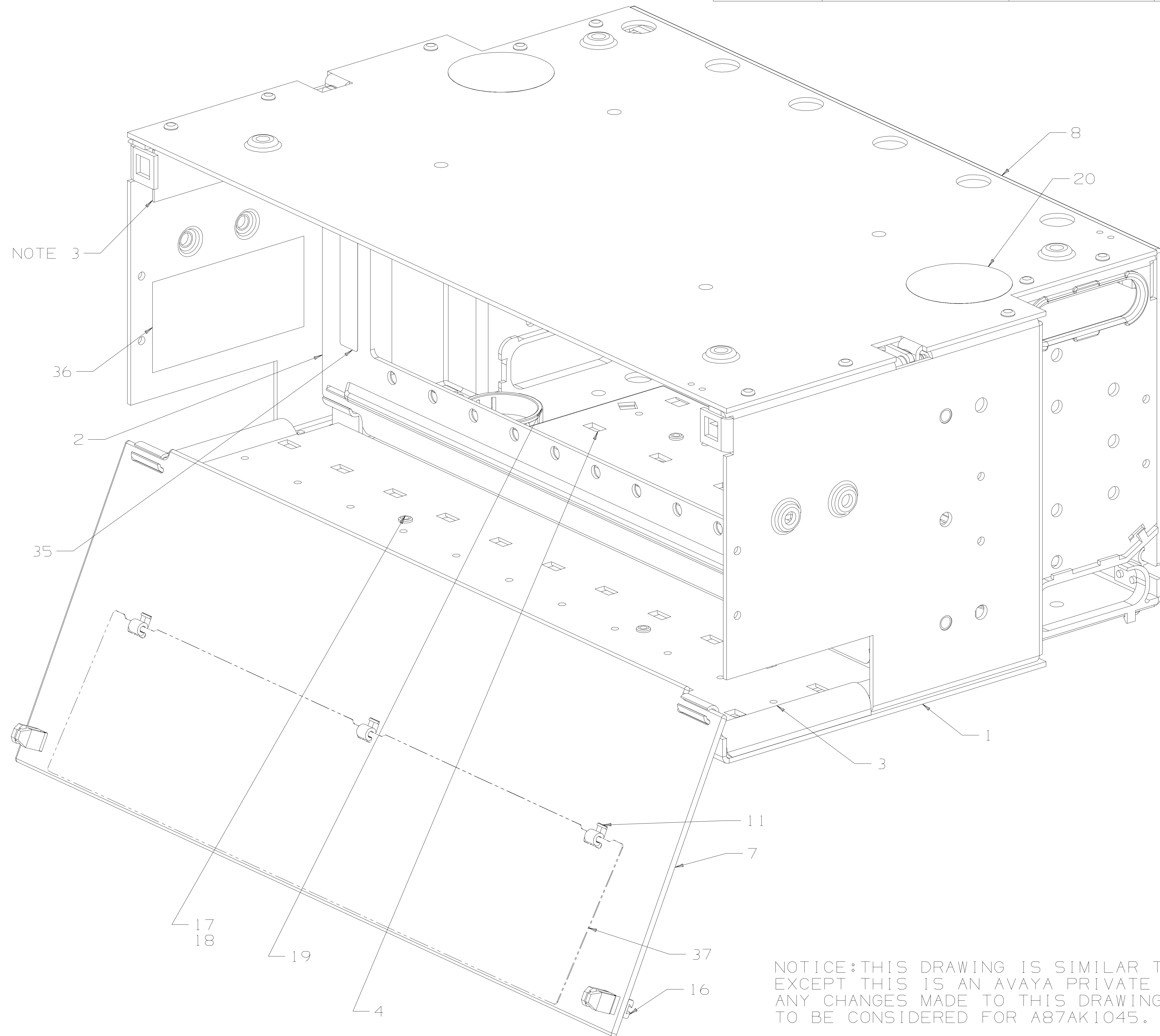

1	847089729	LABEL, UL	40
2	405592221	GROMMET, HEYCO #2237	2 39
1	845866409	INSTRUCTION SHEET	2 38
1	846857068	LABEL - SHELF (SWING)	5 37
2	846836690	LABEL - WARNING	36
1	846857084	LABEL - RACK (BULKHEAD)	2 35
			34
			33
			32
			31
			30
			29
			28
1	847284411	SET OF PARTS (FASTENERS)	2 27
			26
2	901197699	SCREW - CAPTIVE SOUTHCO, #09-13-204-11	4 25
2	901197616	RETAINER-CS SOUTHCO, #09-49-102-42	4 23
			21
2	405110297	HOLE PLUG HEYCO, #2774	20
2	405110263	HOLE PLUG HEYCO, #2764	19
4	405592213	NYLATCH PLUNGER, HN3P-33-3-2	18
4	405469644	NYLATCH GROMMET, HN30-32-2	17
4	405592205	1/4 TURN NYLATCH, HRN6-4-2	16
			15
			14
			13
1	847365053	SET, BEND LIMITERS	2 12
3	847099090	HANGER	5 11
			10
1	847273067	SET OF PARTS, 7" SHELF	2 9
1	846746774	7" DOOR REAR MOLDED	8
1	848807285	7" DOOR, FRONT MOLDED, AVAYA	7
12	845505031	RING - FIBER	2 6
17	847479268	FIBER RETAINER	2 5
1	846810976	RING STAND - REAR MOLDED	4
1	847491370	RING STAND	3
1	847523198	BULKHEAD, , MOLED	2
1	845628528	SHELF SUBASSY - 7"	1

REQ	IDENT NO.	DESCRIPTION	NOTE	ITEM
		STOCKLIST		
1		UNLESS OTHERWISE SPECIFIED, ALL DIMENSIONS ARE IN INCHES. NONLIMITED DIMENSIONS OTHER THAN SIZE OF RAW MATERIAL, SHALL BE HELD AS FOLLOWS WHEN EXPRESSED:		
		TO 2 DECIMAL PLACES ±	AS ANGLES ±	
		TO 3 DECIMAL PLACES ±		
		FOR GENERAL INFORMATION ON SYMBOLS & NOTES REFER TO MFG STD 16003, PART 2, SECT 227.		
		B - PARTIAL ASSEMBLY ON DWG WITH STOCKLIST		
		✓ - QUANTITY AS REQUIRED.		

NOTICE: THIS DRAWING IS SIMILAR TO A87AK1045 EXCEPT THIS IS AN AVAYA PRIVATE LABEL PRODUCT. ANY CHANGES MADE TO THIS DRAWING MAY ALSO NEED TO BE CONSIDERED FOR A87AK1045.

1	1	ISSUE	SHEET
2	1	SHT NO	INDEX

USED ON DRAWING

Lucent Technologies PROPERTY
Use pursuant to Company Instructions

APPARATUS-EQUIPMENT
AVLST1U-072/7
LG
TERMINATION SHELF,
(AVAYA)

SCALE 1/1 & 1/2

BELL LABORATORIES

DWG SIZE A01AK1261
65

SHEET 1 OF 2
GN-97-2013 (1-84)
PRINTED IN U.S.A.