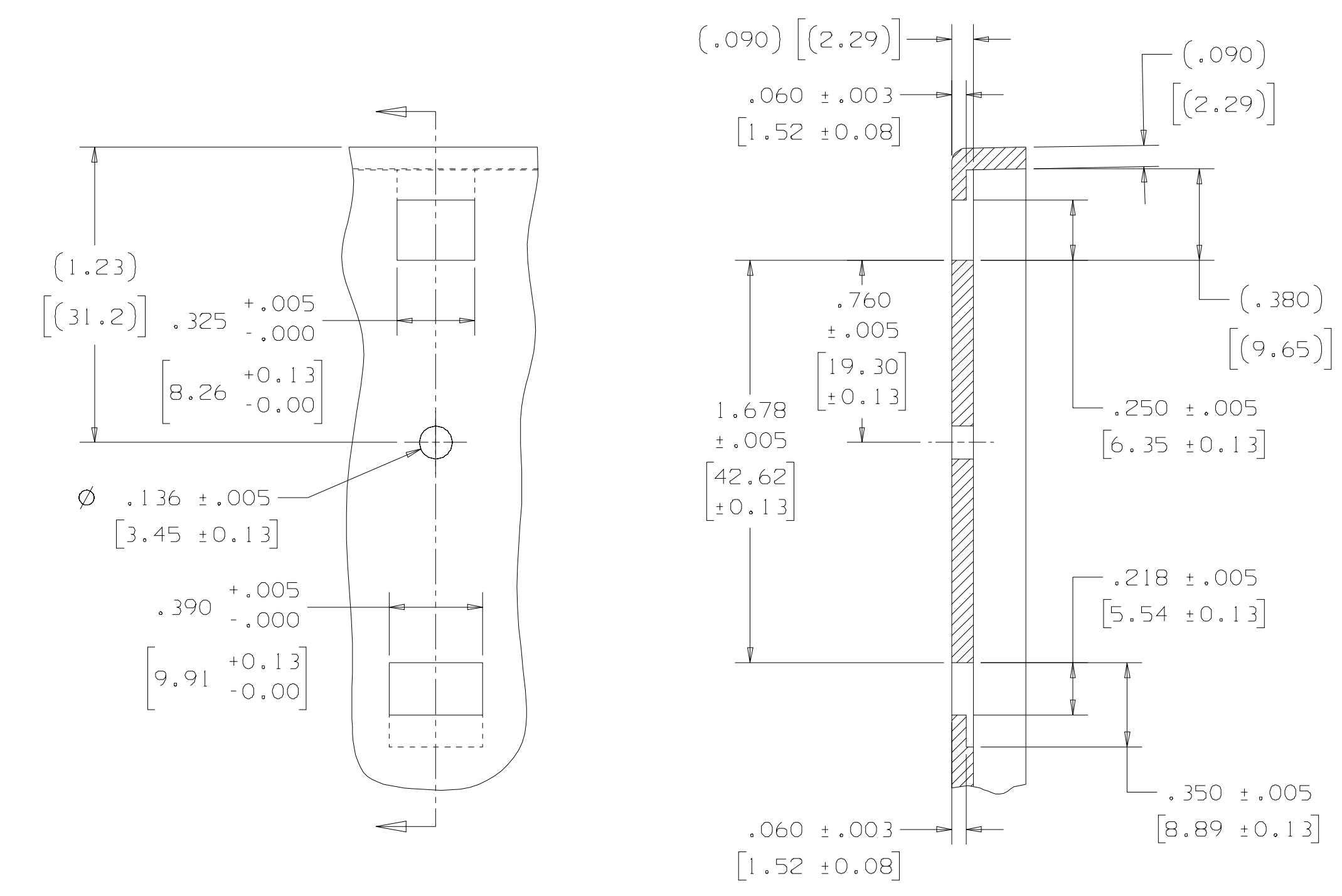
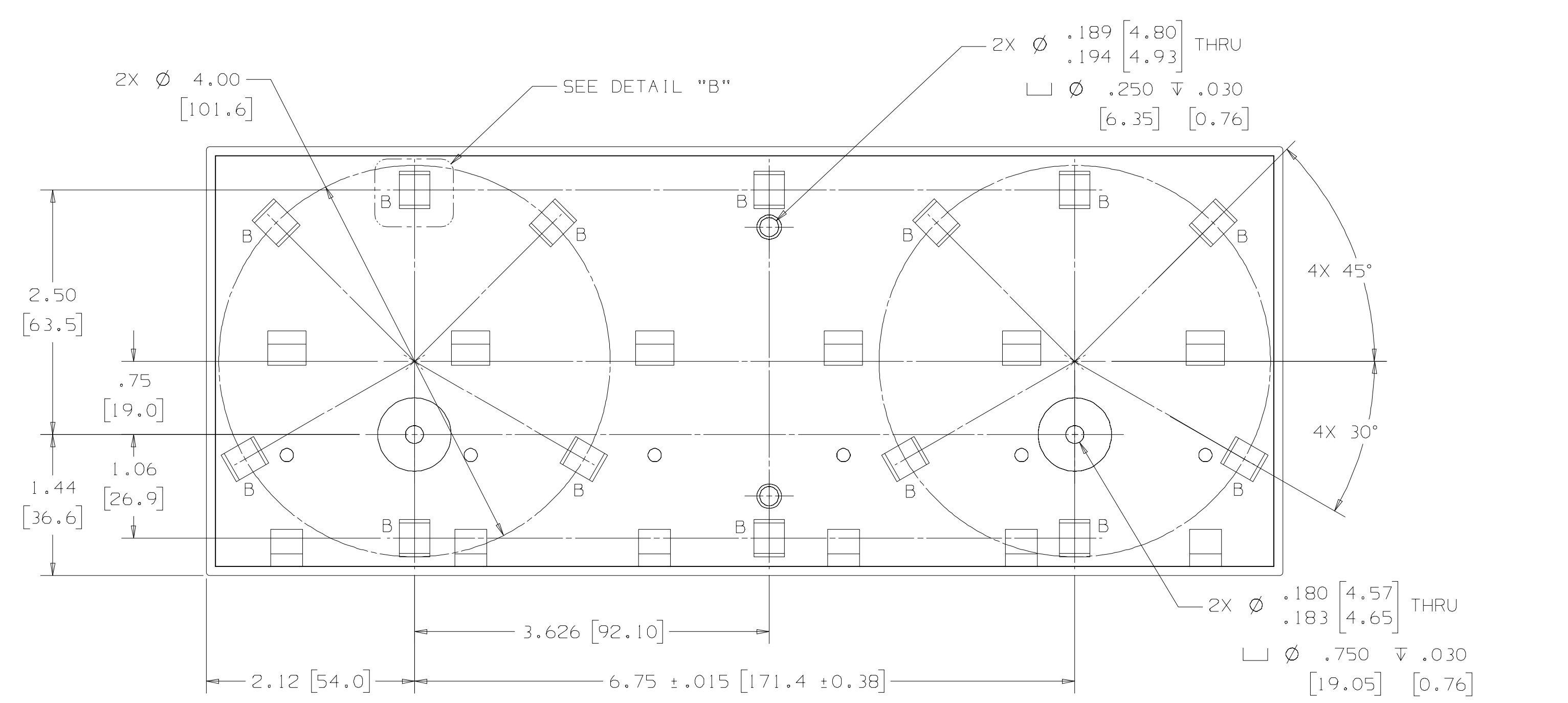
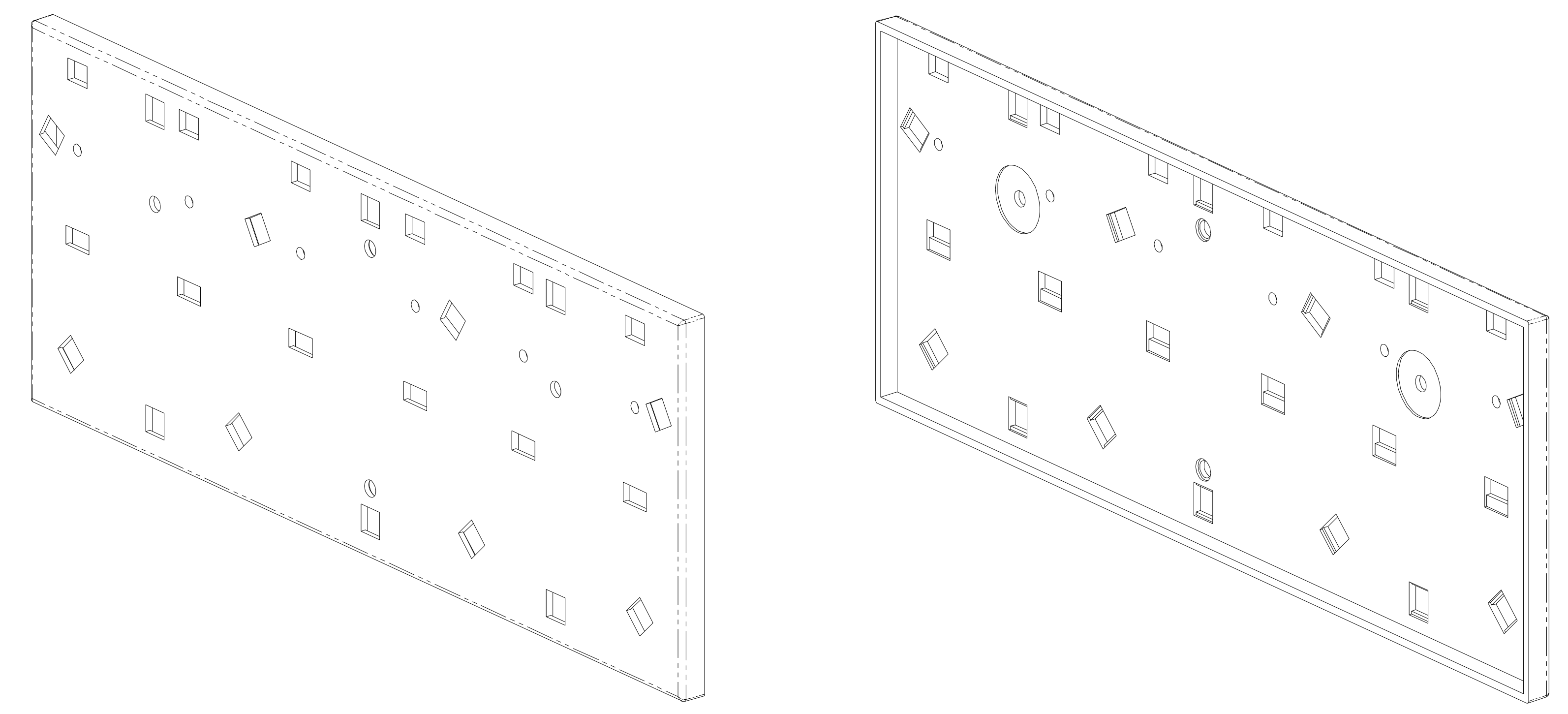

TABLE A		
COMCODE	COLOR	FINISH
D06AK0007-0001	WHITE	NOTE 8A
D06AK0007-0002	BLACK	NOTE 8B

- NOTES:
- UNLESS OTHERWISE SPECIFIED, ALL DIMENSIONS ARE IN INCHES. NONLIMITED DIMENSIONS OTHER THAN SIZE OF RAW MATERIAL SHALL BE HELD AS FOLLOWS WHEN EXPRESSED:
TO 2 DECIMAL PLACES ±.02 (0.5) AS ANGLES ±0.5° TO 3 DECIMAL PLACES ±.010 (0.25)
THIS DRAWING HAS BEEN PREPARED IN ACCORDANCE WITH ANSI Y14.5M - 1994; DIMENSIONS SHOWN IN BRACKETS () ARE MILLIMETERS AND FOR REFERENCE.
 - UNLESS OTHERWISE SPECIFIED, CORNERS SHOWN AS SHARP MAY BE ROUNDED UP TO R .020 (0.50).
 - UNLESS OTHERWISE SPECIFIED, ALL WALL THICKNESSES SHALL BE .090 (2.29).
 - UNLESS OTHERWISE SPECIFIED, ONE DEGREE DRAFT IS PERMITTED WHERE REQUIRED. DIMENSIONS AFFECTED BY DRAFT APPLY TO THE SMALLEST END FOR INTERNAL DIMENSIONS, AND TO THE LARGEST END FOR EXTERNAL DIMENSIONS.
 - UP TO FIVE DEGREES DRAFT IS PERMISSIBLE ON BOTH SIDES OF THESE WALLS.
 - PANEL SHALL BE FLAT AND STRAIGHT WITHIN .030 (0.76) TOTAL.
 - SURFACE FINISH SHALL BE SPE-SPI 3.
 - MATERIAL: POLYCARBONATE MOLDING COMPOUND, PER MS 58547, TYPE 7A. COMPOUND SHALL BE FLAME RETARDANT GRADE 94V-0 AND SHALL RESIST CRACKING WHEN EXPOSED TO SOLVENTS.
A. COLOR: CENTRAL OFFICE WHITE, PER X-SPEC 30001; MAY BE OBTAINED FROM G.E. AS THEIR LEXAN ML 6124, COLOR GEP XS 18719; OR FROM MILES, INC. AS THEIR MAKROLON 6485, COLOR 3599.
B. COLOR: BLACK; MAY BE OBTAINED FROM MILES, INC. AS THEIR MAKROLON 6485, COLOR 1510.
 - PARTS SHALL BE FREE OF FLASH, GATE VESTIGE AND FOREIGN MATERIALS.

D06AK0007	
ENGR J.A. FANL	JAF JF
DRAWN S.R. ANDREWS	SRA WCW
03-03-06 ISSUE 1	



DETAIL A
SCALE 2/1
(TYP 6 PLACES MARKED "A")

DETAIL B
SCALE 2/1
(TYP 14 PLACES MARKED "B")

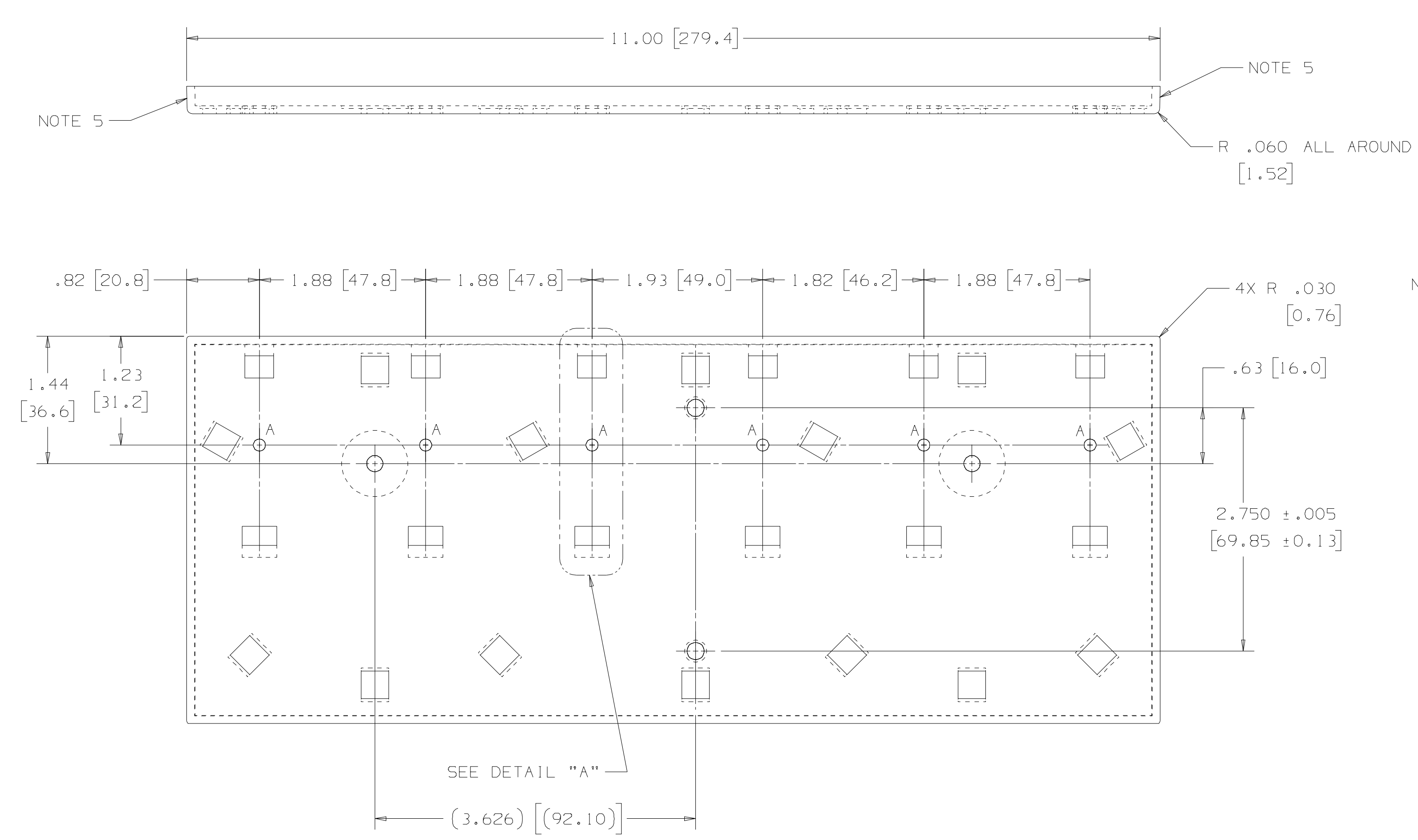

A95AK1006
A01AK1312
AB7AK1045
USED ON
DRAWING

TITLE
RING STAND,
REAR
(MOLDED)

SCALE: 1/1 AND AS NOTED
OFS 2000 N.E. EXPRESSWAY,
NORCROSS, GA. 30071
COMCODE: SEE TABLE "A"

D06AK0007

OFS - PROPRIETARY
Copyright © 2006
FITEL USA, Corp.

SHEET 1 OF 1
DWG SIZE E