



A Furukawa Company

Handling Procedures for AccuRiser™ Indoor/Outdoor Ribbon Cable

Contents	Section
General	1
Precautions	2
Manholes	3
Cable Routing and Racking	4
Cable Coiling in Manholes	5
Cable Coiling in Handholes	6
Pulling Slack Cable	7
Transferring a Cable Bight Through the Manhole Opening	8
Additional Documentation	9

1. General

1.1 This document provides handling instructions and precautions for AccuRiser™ Indoor/Outdoor Ribbon Cable. It is intended for personnel with prior installation experience with optical fiber cables. A working knowledge of cable placing tools, equipment, and procedures is necessary as this guide does not cover all details of optical fiber cable installation.

1.2 *AccuRiser* cable is an all-dielectric, central tube cable (Figure 1). The cable is rated for indoor/outdoor and building applications and is available with 288 – 864 fibers. The *AccuRibbon*® units are comprised of 24 optical fibers that are bonded together in a matrix material. The individual *AccuRibbon* units are stacked together and surrounded by a water-blocking tape and central core tube. The central core tube is surrounded by two layers of helically applied dielectric strength members. Two rip cords are included in the outer layer of strength members to facilitate sheath removal. The cable construction is completed with a LSZH outer jacket making the cable ideal for central office, data center, and building-to-building applications.

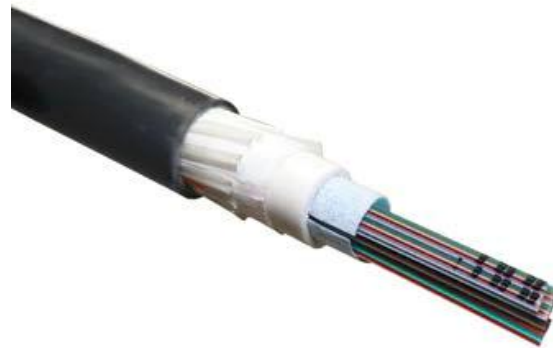

Figure 1 –*AccuRiser* Indoor/Outdoor Ribbon Cable

2. Precautions

2.1 *AccuRiser* cable is designed to meet the rigors of both outside plant and indoor building installations. However, care must be exercised during installation to ensure that the maximum rated cable load (MRCL) is not exceeded and the minimum cable bend diameter is not violated.

2.2 The MRCL for *AccuRiser* cable is 600 pounds (2700 N). This is the maximum tensile force that may be applied to the cable during short-term installation conditions, e.g., during an underground installation in conduit or innerduct. For long term conditions, the maximum permissible load is 180 lb (800 N).

2.3 Cable minimum bend diameters are expressed as a multiple of the cable outside diameter (OD) and are specified for both static and dynamic conditions. For static conditions, the minimum recommended bend diameter is 30 × OD. This condition applies to a cable that is exposed only to low tension, e.g., an installed cable that is racked in a manhole. For dynamic conditions, the minimum recommended bend diameter is 40 × OD. The dynamic condition applies during installation when the cable is pulled around a cable sheave, quadrant block, or capstan winch. Note that quadrant blocks must be designed for use with fiber optic cables. Three-block rollers or similar hardware intended for use with wire rope are not suitable for use with fiber optic cable. For slack cable storage, the minimum recommended coil diameter is 40 × OD. In some cases temporary bending of cable storage-coils into smaller diameters may be necessary to pass cable coils into a manhole; however, the cable should not be bent smaller than that recommended for static conditions under any circumstance. The minimum recommended bend diameters for *AccuRiser* cables are summarized in Table 1.

Table 1 – Minimum Recommended Bend Diameters for *AccuRiser* Cable

Fiber Count	Cable Diameter	Static Condition 30 × OD	Dynamic Condition 40 × OD	Storage Coil 40 × OD
288	0.67 in.	21 in.	27 in.	27 in.
576	0.77 in.	24 in.	31 in.	31 in.
864	0.96 in.	29 in.	39 in.	39 in.

3 Manholes

3.1 Manholes and handholes must be of adequate size to accommodate cable sheaves and/or quadrant blocks that may be used during cable installation. The manholes should be equipped with pulling irons that can be used to rig pulling sheaves and/or quadrant blocks that may be used during cable installation. The manholes should also be equipped with cable racks to support and secure the cable and storage coils to the sidewall of the manhole.

3.2 Manholes must be large enough to accommodate the minimum recommended diameter for cable storage coils. For 864f *AccuRiser* cable, the minimum recommended manhole dimensions are 48" L x 48" W x 48" H.

3.3 Splayed manholes, i.e., manholes that provide conduit terminations near the sidewalls as shown in Figure 2, are preferred over center-entrance manholes. The splayed manholes provide minimum offset between the duct entrance and sidewall of the manhole thus simplifying cable routing in the manhole.

3.4 Center-entrance manholes can be used; however, caution must be exercised when routing cables to the sidewall of the manhole. Specifically, the cable cannot be sharply bent between the exit of the innerduct and the sidewall of the manhole. The cable must follow a gradual transition to the sidewall and not violate the minimum bend diameter. See Section 4 for further details.

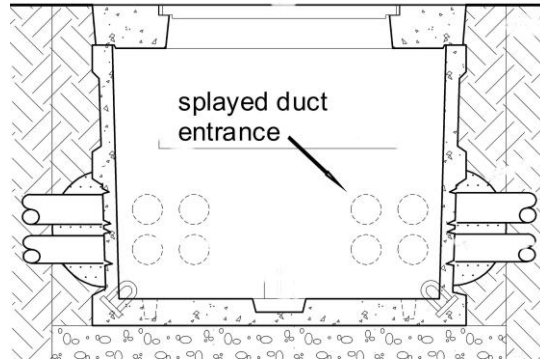

Figure 2 – Splayed manhole showing duct entrance located near sidewall.

4 Cable Routing and Racking

4.1 Care must be exercised during cable routing and racking to accommodate the cable's minimum bend diameter as shown in Figure 3. Ideally, the innerduct should be long enough to reach the first vertical rack in the manhole so that it can be used to support and protect the cable. However, this is feasible only in full size manhole structures.

4.2 In smaller manholes, the innerduct should be trimmed to within 6" of the duct face. This will maximize the distance between the innerducts and opposite wall so that the cable can be properly routed to the sidewall of the manhole. Exercise caution to avoid kinking the cable at the exit of the innerduct. Because the innerduct is very rigid relative to the cable, the innerduct provides a fulcrum point where the cable may be inadvertently kinked. In center-entrance manholes, split conduit-bends can be used to support and guide the cable as it is routed to the sidewall of the manhole. The split conduit bends must meet the minimum bend diameter of the cable. Use cable ties and vinyl tape as required to attach the split conduit bends to the innerduct and cable. In some circumstances, it may be desirable to fasten the cable to existing cables that are already racked in the manhole. Fastening the cables together will provide additional support to help maintain the cable bend radius. Use plastic cable ties as required to fasten and support the cables to each other and/or to the manhole cable racks.

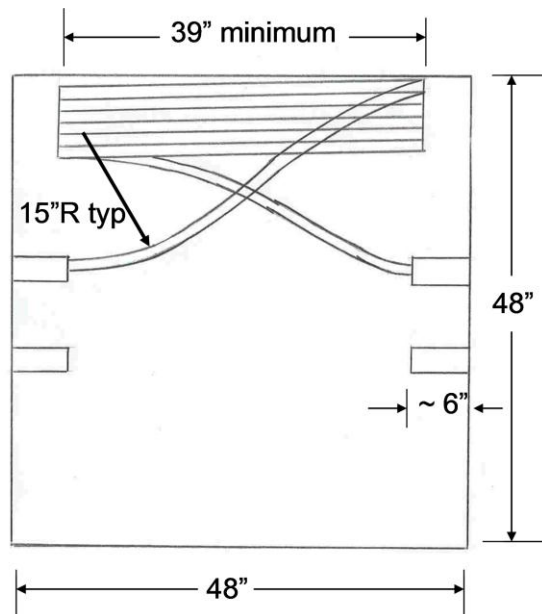

Figure 3 – Routing 864f AccuRiser cable in a 48" x 48" manhole (top view).

5 Cable Coiling in Manholes

5.1 Cable Storage at Mid-Span Locations: In mid-span manhole applications, the recommended coiling method for *AccuRiser* cable is the Garden Hose Method. With this method, the storage coil is formed one coil at a time in the manhole. Alternatively, the coils can be formed at street level and passed through the manhole opening one coil at a time. Coiling the entire length of slack cable at street level and then passing it through the 30" diameter manhole opening is not recommended. This procedure requires excessive manhandling to squeeze the multiple cable coils through the manhole opening and may cause inadvertent cable damage.

5.2 The Garden Hose Method is shown in Figure 4. First, the cable slack is laid out at street level. Next, cable slack is fed through the manhole opening and the first coil is formed in the manhole. Alternatively, the coil can be formed at street level and passed through the manhole opening one coil at a time. In this case, it is relatively easy to temporarily squeeze the coil through the manhole opening. After passing the coil into the manhole, the coil must be resized to meet the minimum diameter for permanent storage. Note that as each cable coil is formed, a cable twist is induced into the remaining slack cable. After a few coils have been formed, the cable twists will be visible as a cork-screw shape in the slack cable. When this occurs, the next cable coil should be formed by twisting the cable in the opposite direction. Note that the crossover point of this loop will be located on the underside of the cable loop. Continue alternating successive layers of right- and left-hand coils as required to eliminate cable twist in the remaining cable slack. When formed correctly, the finished storage coil will be twist-free.

5.3 Adjust the diameter of the coils to absorb any remaining cable slack into the storage coil. Do not decrease the diameter of the storage coil. If the remaining slack cable is too short to form another loop, increase the diameter of the storage coils to absorb the remaining slack. Secure the storage coil to the cable racks with plastic cable ties.

5.4 Be sure to maintain the cable's minimum bend diameter at the exit of the innerduct. Use caution when racking the storage coil on the side wall of the manhole. Do not sharply bend or kink the cable at the exit of the innerduct.

5.5 Cable Storage at Splice Locations: The Garden Hose Method is also recommended for use at cable splice locations. This applies to un-spliced cable ends, splice closures, and mid-span splice closures. The procedure is the same as described in Sections 5.1 – 5.4. However, in these cases, the free-end of the cable or splice closure can be rotated to eliminate cable twist as successive coils are formed. By twisting the free cable-end or splice closure, cable twist is eliminated and the storage coil can be formed in one continuous direction.

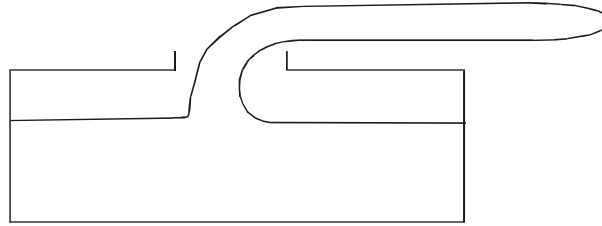

Step 1. Lay out the cable slack.

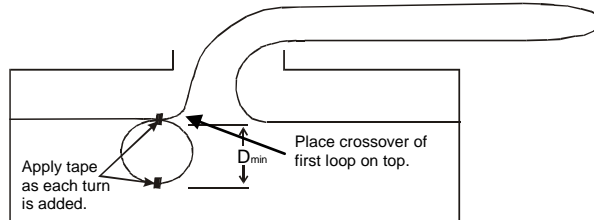

Step 2. Form the first turn in the cable.

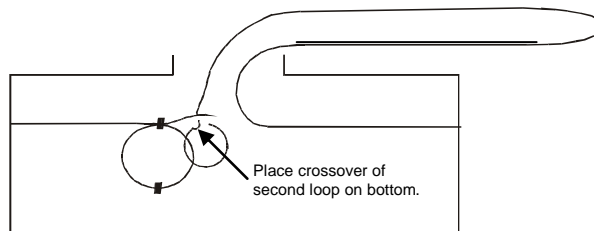

Step 3. Add the second turn by twisting the cable in the opposite direction to form the loop. The crossover point of the second turn should be on the bottom of the loop.

Step 4. Repeat Steps 2 and 3 until all the cable slack has been placed in the coil. Add successive left- and right-hand turns by twisting the cable in the opposite direction for each successive loop. **Caution: Continuous twisting of the cable in the same direction may cause excessive twist and cable damage.**

Figure 4 – Garden Hose Method

6 Cable Coiling in Handholes

6.1 Cable Storage at Mid-Span Locations: For handhole applications, the full length and width of the handhole are exposed when the handhole cover is removed. In these cases, a full-sized storage coil can be formed at ground level and installed in the handhole without having to squeeze the storage coil through a 30" diameter manhole opening. In this application, the preferred coiling method is the Fold-Over Method.

6.2 The Fold-Over Method is illustrated in Figure 5. In this method, the cable is laid out at street level with both legs of the cable bight being equal length. Successive coils are formed by crossing the legs of the cable bight and “folding over” the cable loop to form successive coils. Use vinyl tape as required to maintain the minimum coil diameter and secure successive layers of the storage coil. Continue the process until the entire length of slack cable has been coiled. Install the storage coil in the handhole and adjust the coil diameter to absorb any remaining cable slack into the storage coil. Do not decrease the diameter of the storage coil. If the remaining slack cable is too short to form another loop, increase the diameter of the storage coils to absorb the remaining slack. Secure the storage coil to the cable racks with plastic cable ties.



Step 1. Lay out cable bight. Be sure to observe the cable minimum bend diameter.

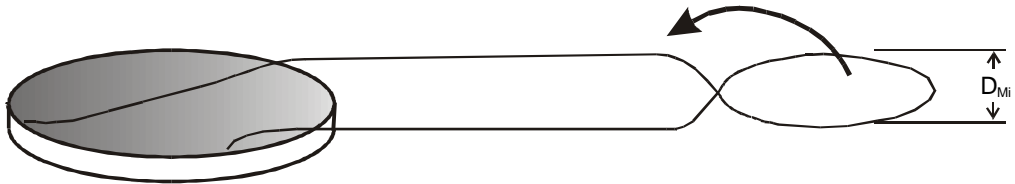

Step 2. Twist cable bight to form the first coil.

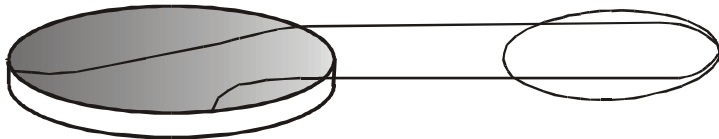

Step 3. Fold over the first coil.

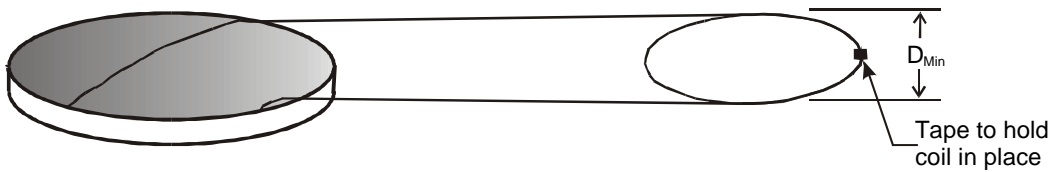

Step 4. Adjust size and tape first coil.

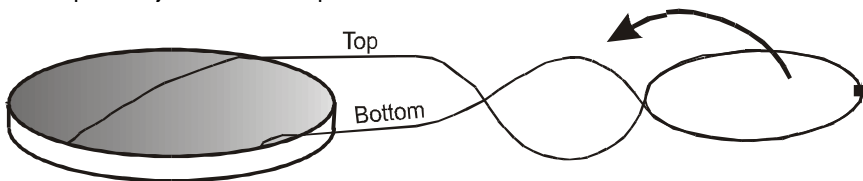

Step 5. Twist the cable bight to form the next coil and fold over.

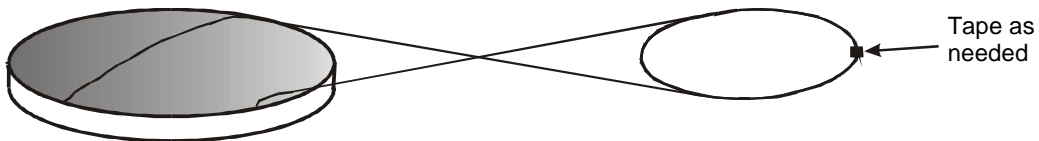

Step 6. Continue to form and fold coils until all of the cable has been coiled.

Figure 5 – Fold-Over Method (handhole applications only).

6.3 Cable Storage at Splice Locations: For handhole applications, un-spliced cable ends should be rolled into a storage coil as shown in Figures 4 and/or 5. Splice closures and mid-span splice closures can be coiled using either the Garden Hose Method (see Section 5.4) or as shown in Figure 5. In either case, these coiling methods will produce a twist-free storage coil. In all cases, the storage coil must meet the minimum storage coil diameter specified in Table 1.

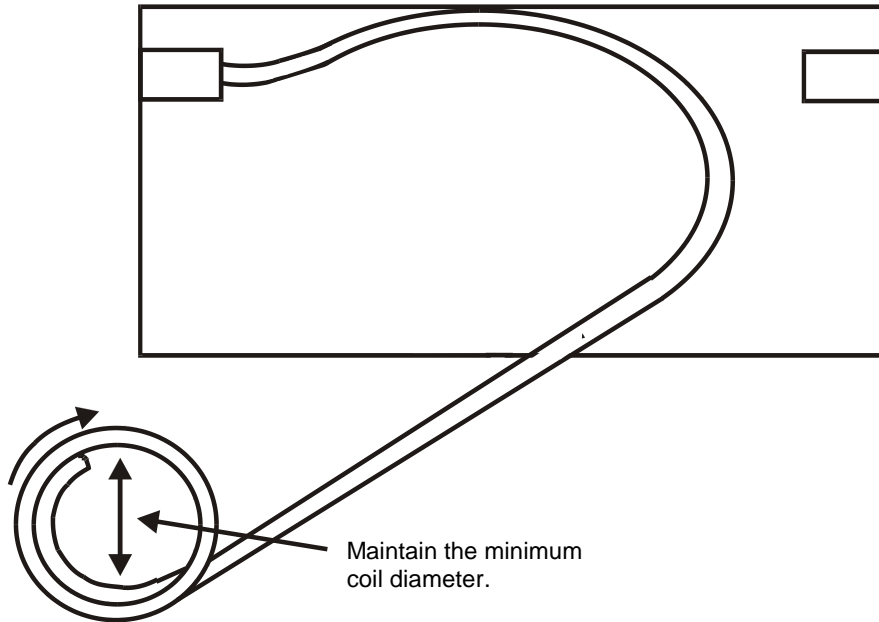

Figure 4 – Rolling the cable into a coil (handhole application only).

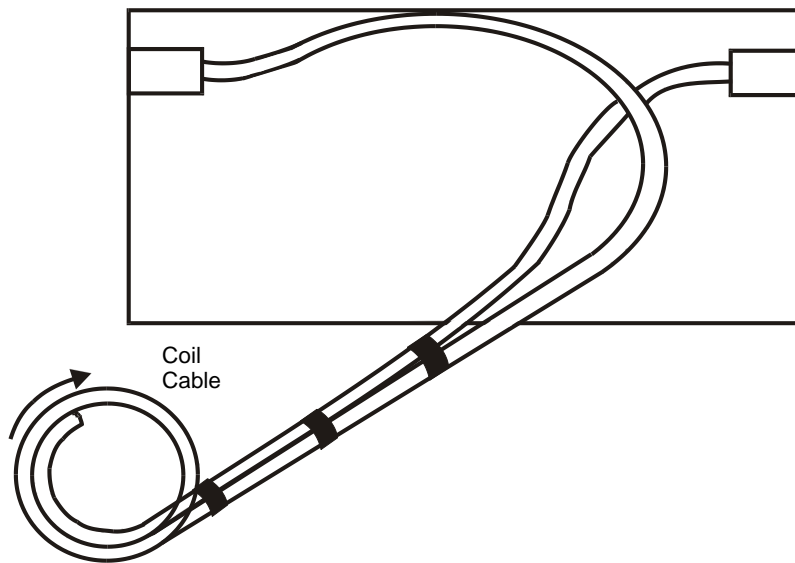

Figure 5 – Rolling two cables together in preparation for splicing (handhole application only).

7 Pulling Slack Cable

7.1 Exercise care when pulling or rearranging cable slack in the conduit and manhole system. In particular, exercise caution to prevent kinking the cable at the entrance or exit of the innerducts, or in the center of the cable bight. In a 48" x 48" (L x W) manhole, the innerducts should be trimmed so that they do not extend more than 6" into the manhole. This leaves a relatively short 36" gap between the entrance and exit innerducts. Two craftsmen should be available when pulling the slack cable - one to pull the cable and the second to manage the slack cable. Additional craftsmen are required in the adjacent manhole to feed slack cable. If the cable is difficult to move by hand, carefully push the cable from the adjacent manhole or apply pressurized air to the innerduct¹ to help move the cable.

7.2 Pull the cable straight out of the innerduct. Do not pull the cable against the edge of the innerduct as this may flatten or kink the cable. Be sure to observe the minimum bend diameter of the cable between the entrance and exit innerducts.

8 Transferring a Cable Bight Through the Manhole Opening

8.1 Exercise caution when removing slack cable from mid-span or intermediate manholes. Under low tension conditions, the cable's minimum bend diameter is just small enough to pass through a standard-sized manhole opening. Form the diameter of the cable bight as large as possible when passing it through the manhole opening. After the cable bight has passed through the manhole opening, increase the diameter of the cable bight to avoid accidental damage.

8.2 If desired, a snowshoe or similar device can be used as a guide to maintain the diameter of the cable bight as it is passed through the manhole opening. Remove the snowshoe once the cable loop has passed through the manhole opening.

9 Additional Documentation

9.1 Please refer to Table 2 for a list of additional OFS documentation regarding cable installation, handling, sheath prep, cable entry tools, and ribbon access.

Table 2 – Additional Documentation

Document Number	Title
IP-003	Aerial Installation Guidelines for Fiber Optic Cable
IP-009	Placing Fiber Optic Cable in Underground Plant
IP-012	Direct Buried Cable Installation
IP-050	Core Tube Blocking Procedure for Central Core Optical Fiber Cable
IP-052	Span Length Recommendations for Optical Fiber Cable in Aerial Innerduct
IP-053	<i>AccuRibbon</i> Cable Handling Precautions
IP-054	1050 Series Core Tube Entry Tools
(continued next page)	

¹ For example, the pressure chamber of a cable blowing machine can be used to inject pressurized air into the innerduct from the adjacent manhole.

Table 2 (cont.) - Additional Documentation

Document Number	Title
IP-057	Splitting 24-Fiber <i>AccuRibbon</i> into 12-Fiber Subunits
IP-061	<i>AccuRibbon DuctSaver</i> End-Prep and Mid-Span Sheath Removal (Dielectric Cable)
IP-079	Sizing Handholes for Fiber Optic Cable

For additional information please contact your sales representative. You can also visit our website at www.ofsoptics.com or call 1-888-FIBER-HELP (1-888-342-3743) from inside the USA or 1-770-798-5555 from outside the USA.

AccuRibbon is a registered trademark and AccuRiser is a trademark of OFS FITEL, LLC.

OFS reserves the right to make changes to the document at any time without notice. This document is for informational purposes only and is not intended to modify or supplement any OFS warranties or specifications relating to any of its products or services. OFS makes no warranty or representation with respect to the non-OFS products or non-OFS companies mentioned in this document.

***Copyright © 2015 OFS FITEL, LLC.
All rights reserved, printed in USA.***